

**ROOF HATCH - Diamond Series™** - ROOF HATCH, DIAMOND SERIES 30 X 96 | ALUM, MILL FINISH

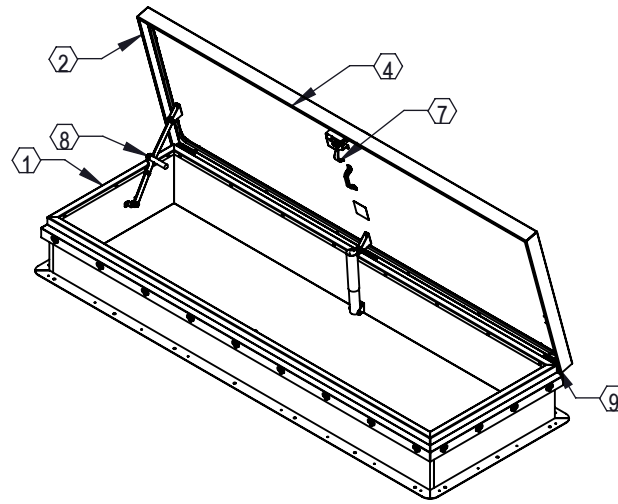
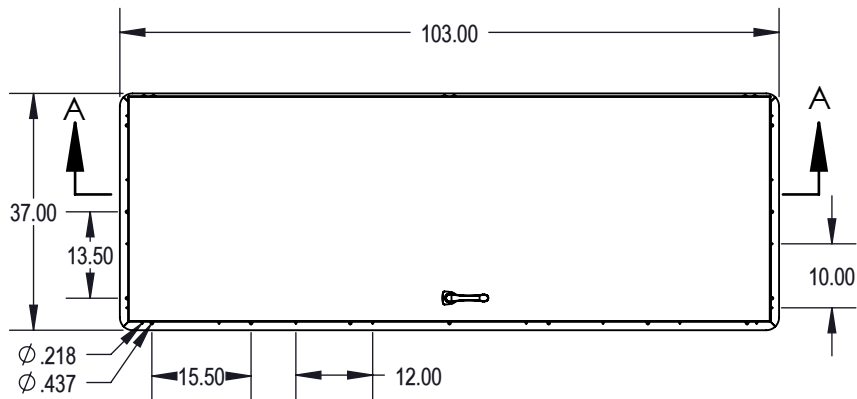

**SPECIFICATIONS:**

1. Curb: 11 gauge mill finish aluminum single wall curb and counterflashing with Diamond Grip.
2. Cover: 11 gauge aluminum formed, welded cover with 18 gauge liner, tested to support a live load of 40psf.
3. Finish: Mill Finish.
4. Gasket: Continuous, weatherproof EPDM sponge rubber adhesive-backed seal.
5. Insulation: 1" polyisocyanurate in curb and cover with thermal resistance R-6.
6. Spring: Counterbalanced compression springs contained in clear zinc-plated steel cylinders.
7. Latch: Clear zinc-plated steel slam latch with inside and outside handles and padlock hasps.
8. Hold Open Arm: Clear zinc-plated automatic locking hold open arm with red vinyl grip for one handed door operation.
9. Hinge: Heavy duty clear zinc-plated steel pintle hinge.

**Notes:**

For pitched roofs up to 7:12, mount hinge side parallel to slope.  
 Door opens 75°  
 Clear Opening: 19" X 90"  
 Weight: 133lbs

Diamond Series™ is a trademark of Activar Construction Products Group Inc.

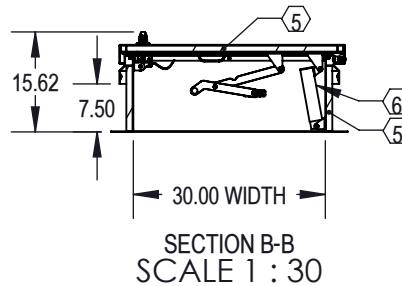
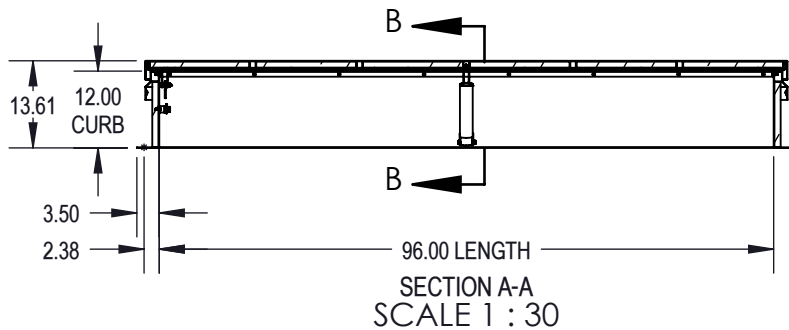

**MODEL #:** RHDA-3



9702 Newton Ave S. Bloomington, MN 55431 | 10 Locations Nationwide

800-554-6077 952-835-2218 sales@activarcpg.com www.activarcpg.com

Distributor:		Project:	
Contractor:		Approved By:	
Date:	Quantity:	Architect:	
Scale:	Pages: 1 OF 1	Drawing #:	RHDA-3-SUBMITTAL_B