

Key-Locking Internal Locking

REVISIONS		DATE	APPROVED
ZONE	REV.	DESCRIPTION	

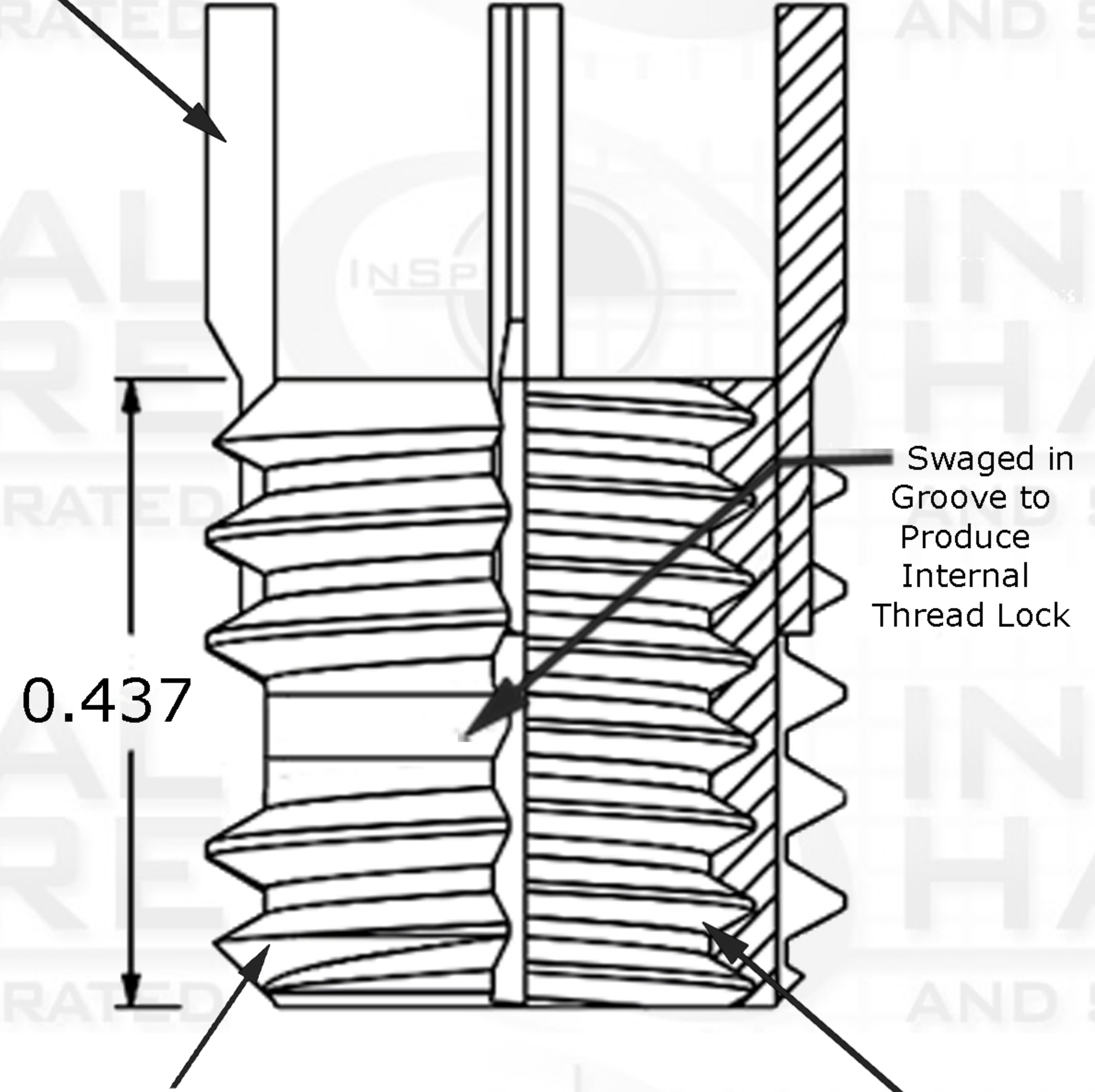

Key



0.437

Swaged in Groove to Produce Internal Thread Lock

External Thread Pitch
7/16-14

Internal Thread Pitch
5/16-18

Suggested Drill Bit Size



0.3970 (Letter X)

PROPRIETARY AND CONFIDENTIAL

THIS DRAWING AND IT'S CONTENT IS THE SOLE PROPERTY OF INDUSTRIAL HARDWARE & SPECIALTIES,INC.. ANY REPRODUCTION IN PART OR AS A WHOLE WITHOUT THE WRITTEN PERMISSION OF INDUSTRIAL HARDWARE & SPECIALTIES,INC. IS STRICTLY PROHIBITED.

		Internal TH. STANDARD : ANSI/ASME ACRONYM: UNC ROTATION: Right-Hand	DRAWN	NAME	DATE
		External TH. STANDARD : ANSI/ASME ACRONYM: UNC ROTATION: Right-Hand	CHECKED		
		MATERIAL FINISH Alloy Steel Type 4140	ENG APPR.		
		PART NUMBER 35L8C-352G-31-0A	MFG APPR.		
NEXT ASSY	USED ON		Q.A.		
		APPLICATION	COMMENTS:		
		DO NOT SCALE DRAWING			



**17-B KENTUCKY AVENUE
PATERSON, NEW JERSEY 07503
TEL: 973-684-4010 FAX: 973-684-3095
email: TechSupport@industrialhardware.com
www.industrialhardware.com**

SIZE A	DWG. NO.	REV.
SCALE:1:8	WEIGHT:	SHEET 1 OF 1