

Key-Locking Non-Locking

ZONE		REV.	REVISIONS	DATE	APPROVED
			DESCRIPTION		

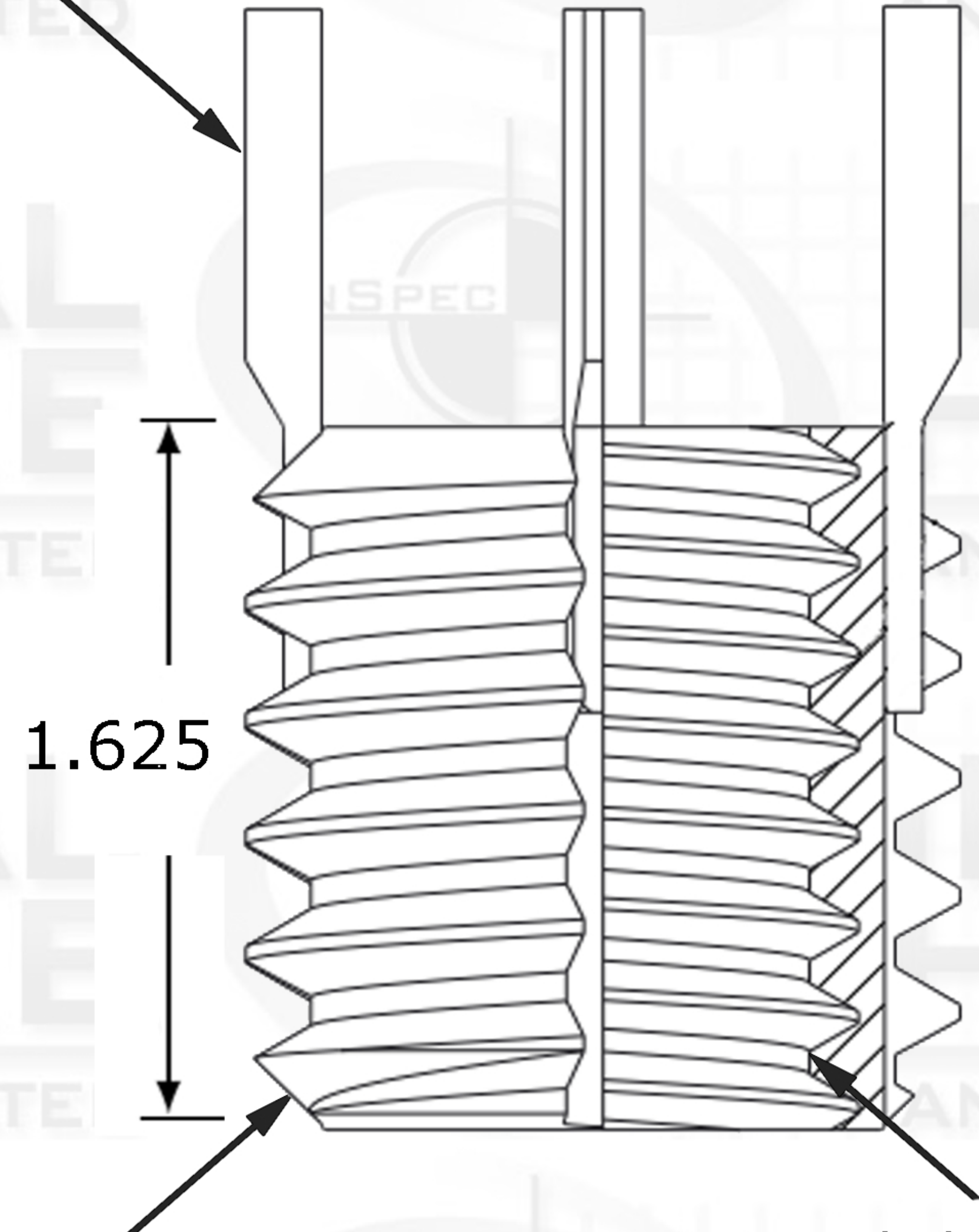

Key



1.625

External Thread Pitch
1-1/2-12

Internal Thread Pitch
1-1/8-12

Suggested Drill Bit Size



1.4375 (1-7/16)

PROPRIETARY AND CONFIDENTIAL

THIS DRAWING AND IT'S CONTENT IS THE SOLE PROPERTY OF INDUSTRIAL HARDWARE & SPECIALTIES,INC.. ANY REPRODUCTION IN PART OR AS A WHOLE WITHOUT THE WRITTEN PERMISSION OF INDUSTRIAL HARDWARE & SPECIALTIES,INC. IS STRICTLY PROHIBITED.

Internal	NAME	DATE
TH. STANDARD: ANSI/ASME	DRAWN	
ACRONYM: UNF	CHECKED	
ROTATION: Right-Hand	ENG APPR.	
External	MFG APPR.	
TH. STANDARD: ANSI/ASME	Q.A.	
ACRONYM: UNF	COMMENTS:	
ROTATION: Right-Hand		
MATERIAL FINISH		
Carbon Steel C1215		
PART NUMBER		
35L8C-4QCG-112		
NEXT ASSY	USED ON	
APPLICATION	DO NOT SCALE DRAWING	



17-B KENTUCKY AVENUE
PATERSON, NEW JERSEY 07503
TEL: 973-684-4010 FAX: 973-684-3095
email: TechSupport@industrialhardware.com
www.industrialhardware.com

SIZE	DWG. NO.	REV.
A		
SCALE:1:8	WEIGHT:	SHEET 1 OF 1