

Key-Locking Non-Locking

REVISIONS		DATE	APPROVED
ZONE	REV.	DESCRIPTION	

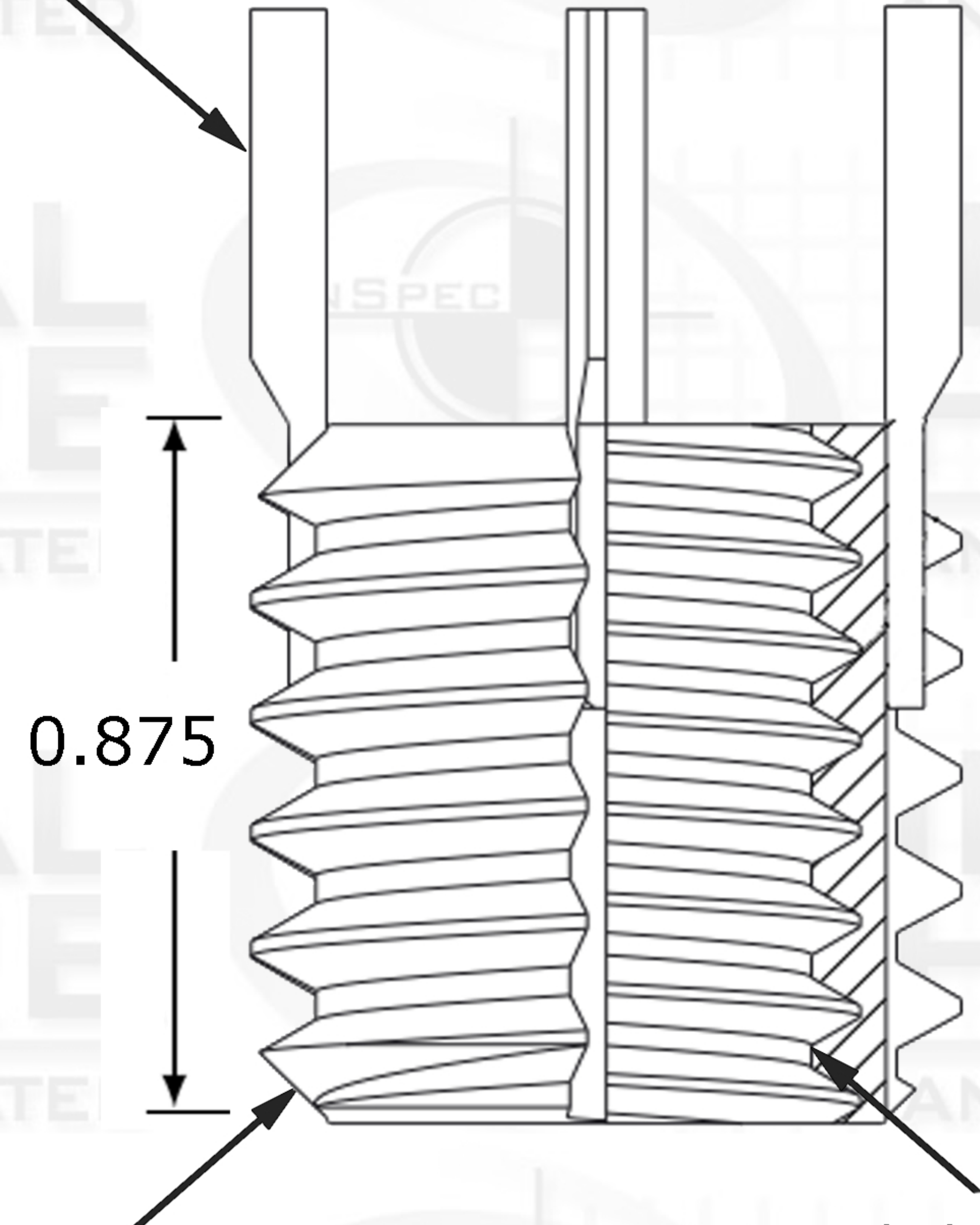

Key



0.875

External Thread Pitch
1-12

Internal Thread Pitch
5/8-11

Suggested Drill Bit Size



0.9375 (15/16)

PROPRIETARY AND CONFIDENTIAL

THIS DRAWING AND IT'S CONTENT IS THE SOLE PROPERTY OF INDUSTRIAL HARDWARE & SPECIALTIES,INC.. ANY REPRODUCTION IN PART OR AS A WHOLE WITHOUT THE WRITTEN PERMISSION OF INDUSTRIAL HARDWARE & SPECIALTIES,INC. IS STRICTLY PROHIBITED.

		Internal	NAME	DATE
		TH. STANDARD: ANSI/ASME ACRONYM: UNC ROTATION: Right-Hand	DRAWN	
		External TH. STANDARD: ANSI/ASME ACRONYM: UNF ROTATION: Right-Hand	CHECKED	
		MATERIAL FINISH Carbon Steel C1215	ENG APPR.	
		PART NUMBER 35L8C-4RB6-062	MFG APPR.	
NEXT ASSY	USED ON		Q.A.	
APPLICATION		DO NOT SCALE DRAWING	COMMENTS:	



**17-B KENTUCKY AVENUE
PATERSON, NEW JERSEY 07503
TEL: 973-684-4010 FAX: 973-684-3095
email: TechSupport@industrialhardware.com
www.industrialhardware.com**

SIZE A	DWG. NO.	REV.
SCALE:1:8	WEIGHT:	SHEET 1 OF 1