

# Key-Locking Internal Locking

REVISIONS		DATE	APPROVED
ZONE	REV.	DESCRIPTION	

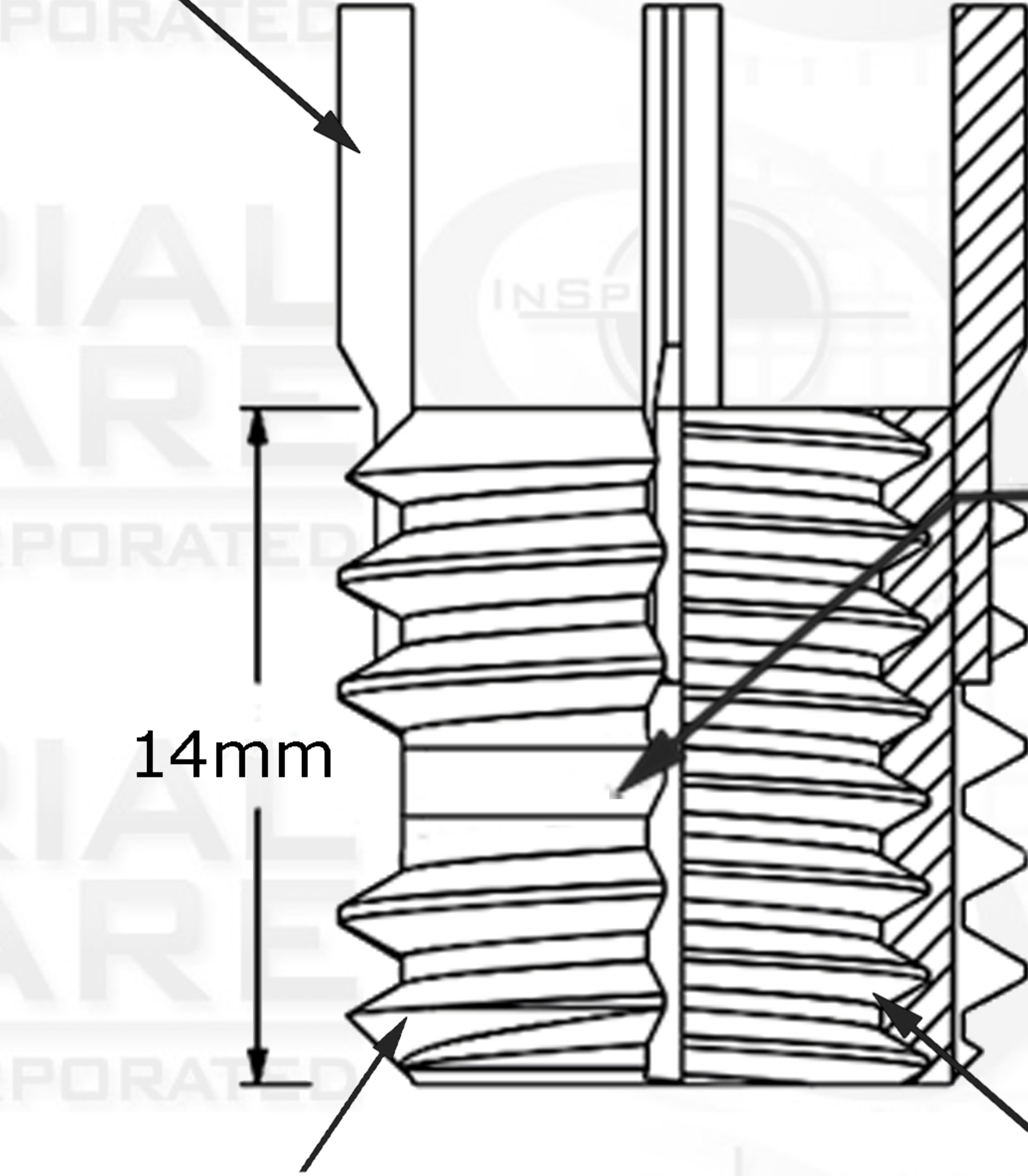

Key



Swaged in Groove to Produce Internal Thread Lock

14mm

External Thread Pitch  
M14 x 1.5

Internal Thread Pitch  
M10 x 1.25

Suggested Drill Bit Size



0.5000 (1/2)

## PROPRIETARY AND CONFIDENTIAL

THIS DRAWING AND IT'S CONTENT IS THE SOLE PROPERTY OF INDUSTRIAL HARDWARE & SPECIALTIES,INC.. ANY REPRODUCTION IN PART OR AS A WHOLE WITHOUT THE WRITTEN PERMISSION OF INDUSTRIAL HARDWARE & SPECIALTIES,INC. IS STRICTLY PROHIBITED.

		<b>Internal</b>		NAME	DATE
		TH. STANDARD : ISO Metric		DRAWN	
		ACRONYM: ISO		CHECKED	
		ROTATION: Right-Hand		ENG APPR.	
		<b>External</b>		MFG APPR.	
		TH. STANDARD : ISO Metric		Q.A.	
		ACRONYM: ISO			
		ROTATION: Right-Hand			
		MATERIAL FINISH			
		Stainless Steel Type 303	COMMENTS:		
NEXT ASSY	USED ON	PART NUMBER			
		35L8C-66T0-C10H-05			
APPLICATION		DO NOT SCALE DRAWING			



17-B KENTUCKY AVENUE  
PATERSON, NEW JERSEY 07503  
TEL: 973-684-4010 FAX: 973-684-3095  
email: TechSupport@industrialhardware.com  
www.industrialhardware.com

SIZE	DWG. NO.	REV.
<b>A</b>		
SCALE:1:8	WEIGHT:	SHEET 1 OF 1