

Key-Locking Internal Locking

| REVISIONS | | DATE | APPROVED |
|-----------|------|-------------|----------|
| ZONE | REV. | DESCRIPTION | |
| | | | |
| | | | |

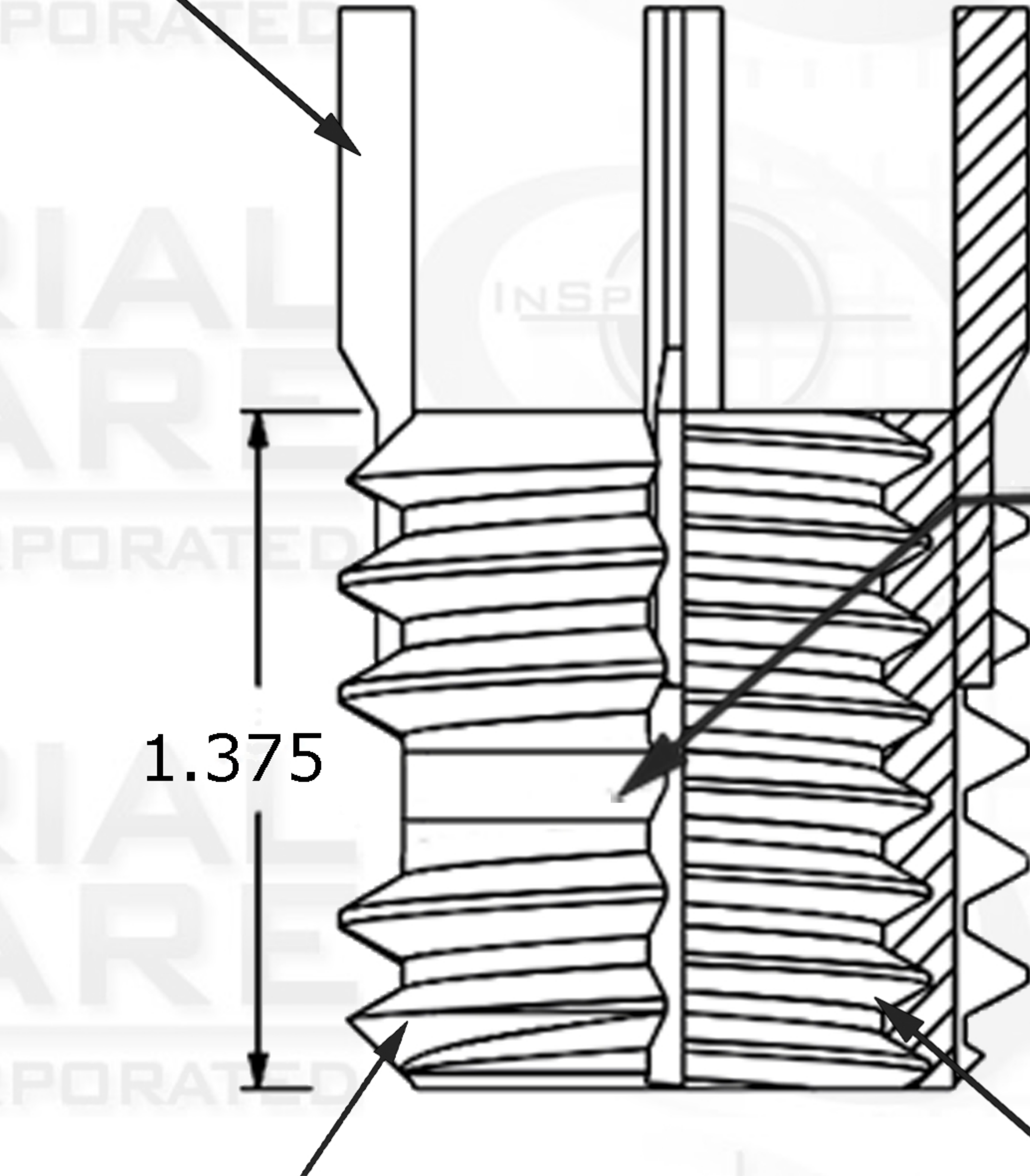

Key



Swaged in Groove to Produce Internal Thread Lock

1.375

External Thread Pitch

1-1/4-12

Internal Thread Pitch

7/8-9

Suggested Drill Bit Size



1.1875 (1-3/16)

PROPRIETARY AND CONFIDENTIAL

THIS DRAWING AND IT'S CONTENT IS THE SOLE PROPERTY OF INDUSTRIAL HARDWARE & SPECIALTIES,INC.. ANY REPRODUCTION IN PART OR AS A WHOLE WITHOUT THE WRITTEN PERMISSION OF INDUSTRIAL HARDWARE & SPECIALTIES,INC. IS STRICTLY PROHIBITED.

| | | | | | |
|-------------|---------|--------------------------|-----------|------|------|
| | | Internal | | NAME | DATE |
| | | TH. STANDARD : ANSI/ASME | DRAWN | | |
| | | ACRONYM: UNC | CHECKED | | |
| | | ROTATION: Right-Hand | ENG APPR. | | |
| | | External | MFG APPR. | | |
| | | TH. STANDARD : ANSI/ASME | Q.A. | | |
| | | ACRONYM: UNF | | | |
| | | ROTATION: Right-Hand | | | |
| | | MATERIAL FINISH | | | |
| | | Stainless Steel Type 303 | COMMENTS: | | |
| NEXT ASSY | USED ON | PART NUMBER | | | |
| | | 35L8C-68P2-087 | | | |
| APPLICATION | | DO NOT SCALE DRAWING | | | |



INDUSTRIAL HARDWARE AND SPECIALTIES INCORPORATED
 17-B KENTUCKY AVENUE
 PATERSON, NEW JERSEY 07503
 TEL: 973-684-4010 FAX: 973-684-3095
 email: TechSupport@industrialhardware.com
 www.industrialhardware.com

| | | |
|-----------|----------|--------------|
| SIZE | DWG. NO. | REV. |
| A | | |
| SCALE:1:8 | WEIGHT: | SHEET 1 OF 1 |