

Key-Locking Non-Locking

ZONE		REV.	REVISIONS	DATE	APPROVED
			DESCRIPTION		

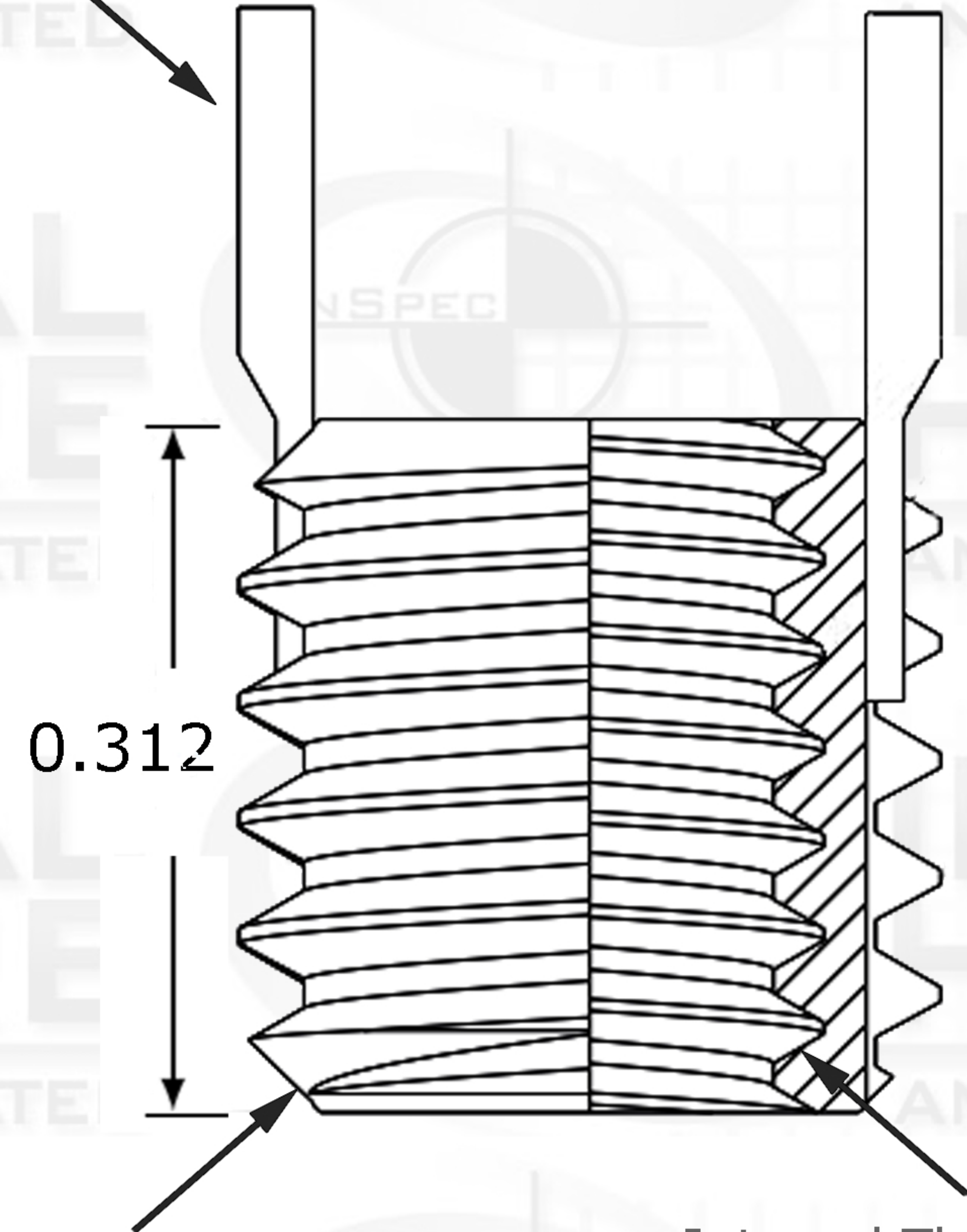

Key



0.312

External Thread Pitch
5/16-18

Internal Thread Pitch
8-32

Suggested Drill Bit Size



0.2720 (Letter I)

PROPRIETARY AND CONFIDENTIAL

THIS DRAWING AND IT'S CONTENT IS THE SOLE PROPERTY OF INDUSTRIAL HARDWARE & SPECIALTIES,INC.. ANY REPRODUCTION IN PART OR AS A WHOLE WITHOUT THE WRITTEN PERMISSION OF INDUSTRIAL HARDWARE & SPECIALTIES,INC. IS STRICTLY PROHIBITED.

		Internal		NAME	DATE
		TH. STANDARD: ANSI/ASME	DRAWN		
		ACRONYM: UNC	CHECKED		
		ROTATION: Right-Hand	ENG APPR.		
		External	MFG APPR.		
		TH. STANDARD: ANSI/ASME	Q.A.		
		ACRONYM: UNC			
		ROTATION: Right-Hand			
		MATERIAL FINISH			
		Stainless Steel Type A286			
NEXT ASSY	USED ON	PART NUMBER	COMMENTS:		
		35L8C-7T0W-08-0A			
APPLICATION		DO NOT SCALE DRAWING			



17-B KENTUCKY AVENUE
PATERSON, NEW JERSEY 07503
TEL: 973-684-4010 FAX: 973-684-3095
email: TechSupport@industrialhardware.com
www.industrialhardware.com

SIZE	DWG. NO.	REV.
A		
SCALE:1:8	WEIGHT:	SHEET 1 OF 1