

Key-Locking Non-Locking

REVISIONS		DATE	APPROVED
ZONE	REV.	DESCRIPTION	

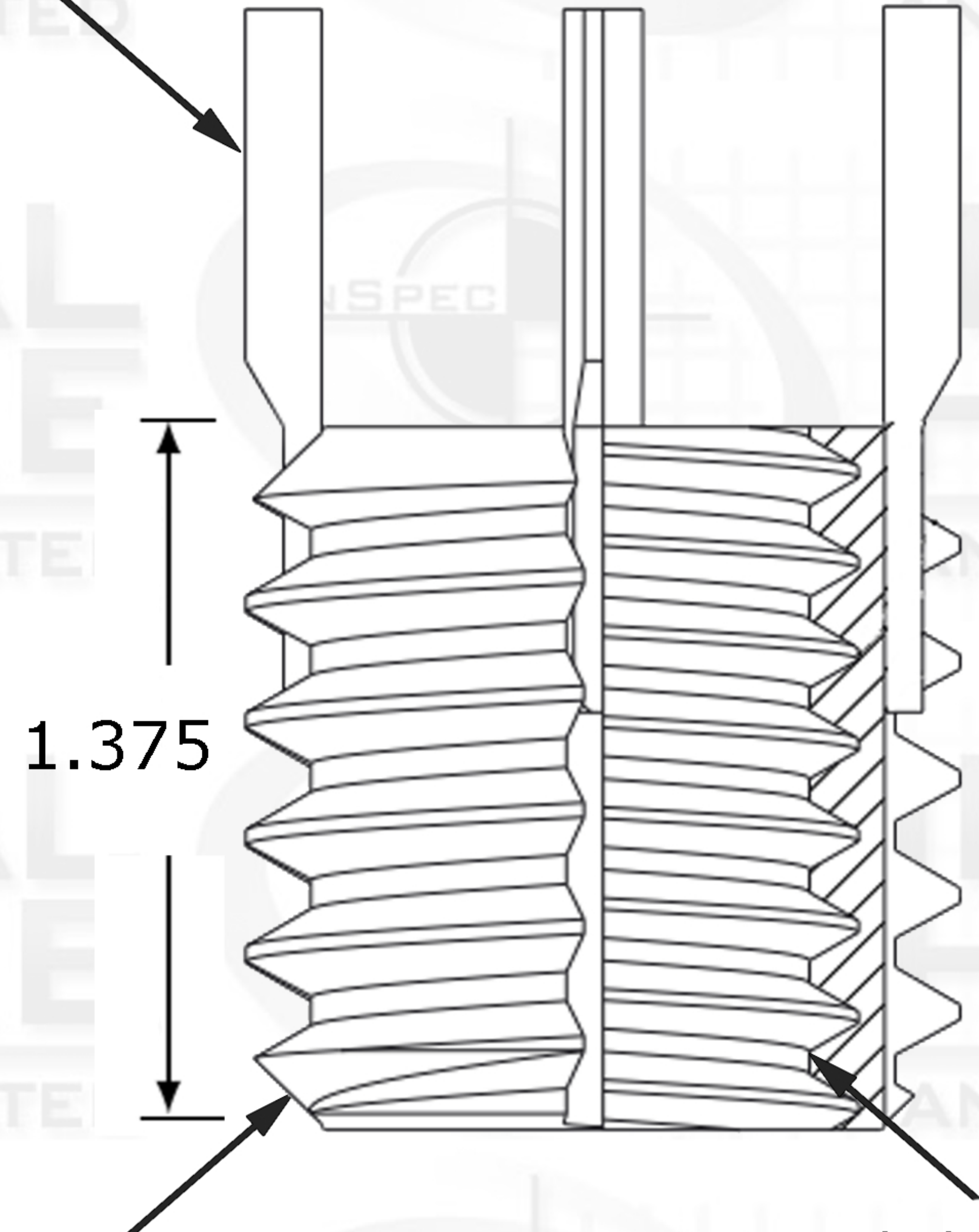

Key



1.375

External Thread Pitch
1-3/8-12

Internal Thread Pitch
1-8

Suggested Drill Bit Size



1.3125 (1-5/16)

PROPRIETARY AND CONFIDENTIAL

THIS DRAWING AND IT'S CONTENT IS THE SOLE PROPERTY OF INDUSTRIAL HARDWARE & SPECIALTIES,INC.. ANY REPRODUCTION IN PART OR AS A WHOLE WITHOUT THE WRITTEN PERMISSION OF INDUSTRIAL HARDWARE & SPECIALTIES,INC. IS STRICTLY PROHIBITED.

Internal	NAME	DATE
TH. STANDARD: ANSI/ASME	DRAWN	
ACRONYM: UNC	CHECKED	
ROTATION: Right-Hand	ENG APPR.	
External	MFG APPR.	
TH. STANDARD: ANSI/ASME	Q.A.	
ACRONYM: UNF		
ROTATION: Right-Hand		
MATERIAL FINISH		
Stainless Steel Type A286	COMMENTS:	
PART NUMBER		
35L8C-7T0Y-100-03		
NEXT ASSY	USED ON	
APPLICATION	DO NOT SCALE DRAWING	



17-B KENTUCKY AVENUE
PATERSON, NEW JERSEY 07503
TEL: 973-684-4010 FAX: 973-684-3095
email: TechSupport@industrialhardware.com
www.industrialhardware.com

SIZE	DWG. NO.	REV.
A		
SCALE:1:8	WEIGHT:	SHEET 1 OF 1