

ZONE		REV.	REVISIONS DESCRIPTION	DATE	APPROVED

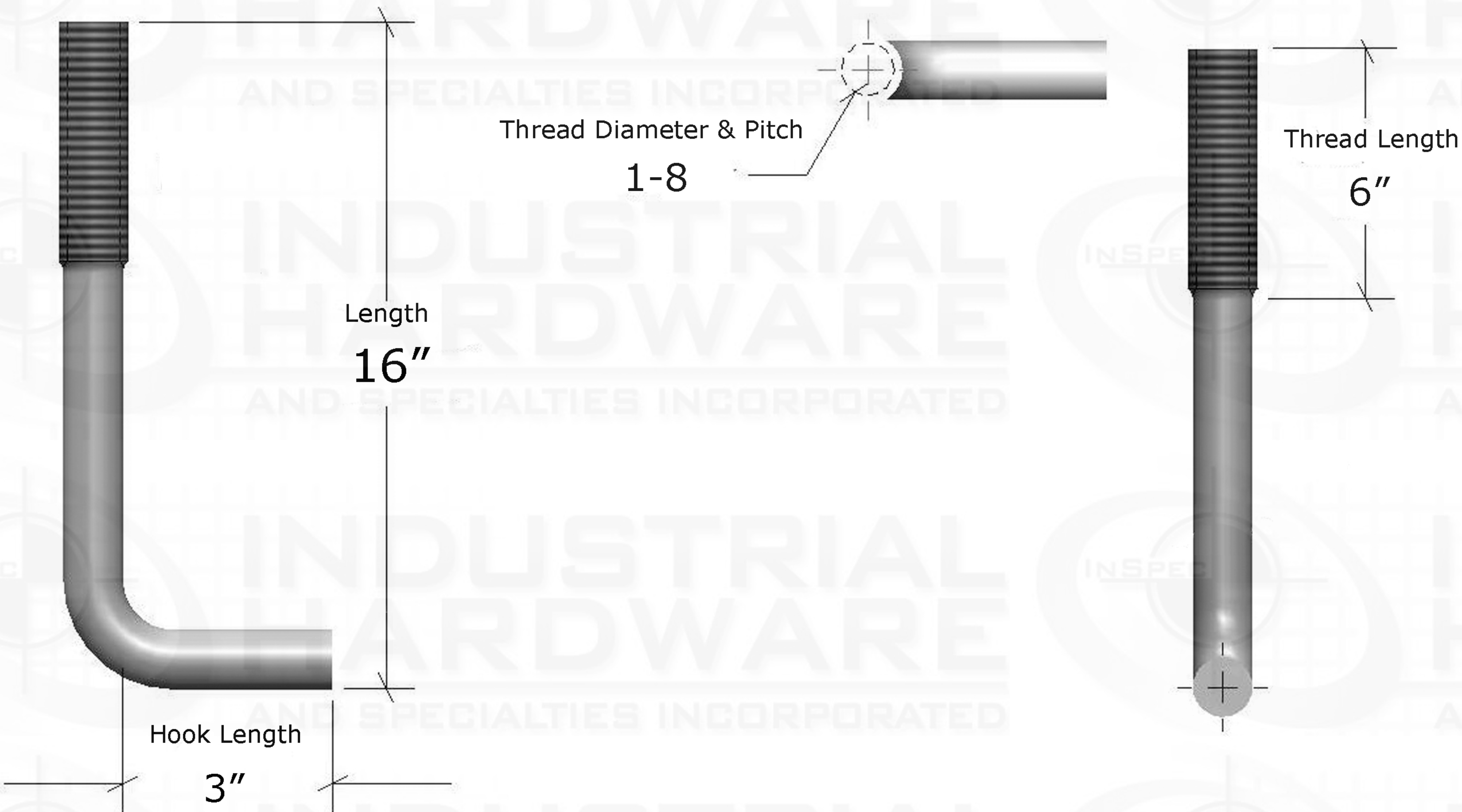

**PROPRIETARY AND CONFIDENTIAL**

THIS DRAWING AND IT'S CONTENT IS THE SOLE PROPERTY OF INDUSTRIAL HARDWARE & SPECIALTIES,INC.. ANY REPRODUCTION IN PART OR AS A WHOLE WITHOUT THE WRITTEN PERMISSION OF INDUSTRIAL HARDWARE & SPECIALTIES,INC. IS STRICTLY PROHIBITED.

DIMENSIONS ARE IN INCHES TOLERANCES: FRACTIONAL $\pm 1/64"$ ANGULAR: MACH $\pm 1^\circ$ BEND $\pm 1^\circ$ TWO PLACE DECIMAL $\pm .01"$ THREE PLACE DECIMAL $\pm .005"$ CONCENTRICITY T.I.R. = $.005"$		NAME	DATE
DRAWN			
CHECKED			
ENG APPR.			
MFG APPR.			
Q.A.			
MATERIAL FINISH ASTM F1554-Grade 55 Plain		COMMENTS:	
NEXT ASSY	USED ON		
PART NUMBER 121-10.16.030.06VP			
APPLICATION		DO NOT SCALE DRAWING	

**INDUSTRIAL HARDWARE AND SPECIALTIES INCORPORATED**

17-B KENTUCKY AVENUE  
PATERSON, NEW JERSEY 07503  
TEL: 973-684-4010 FAX: 973-684-3095  
email: TechSupport@industrialhardware.com  
www.industrialhardware.com

SIZE	DWG. NO.	REV.
<b>A</b>		
SCALE: 1:8	WEIGHT: 3.5627 lbs ea	SHEET 1 OF 1