

		REVISIONS			
ZONE	REV.	DESCRIPTION		DATE	APPROVED

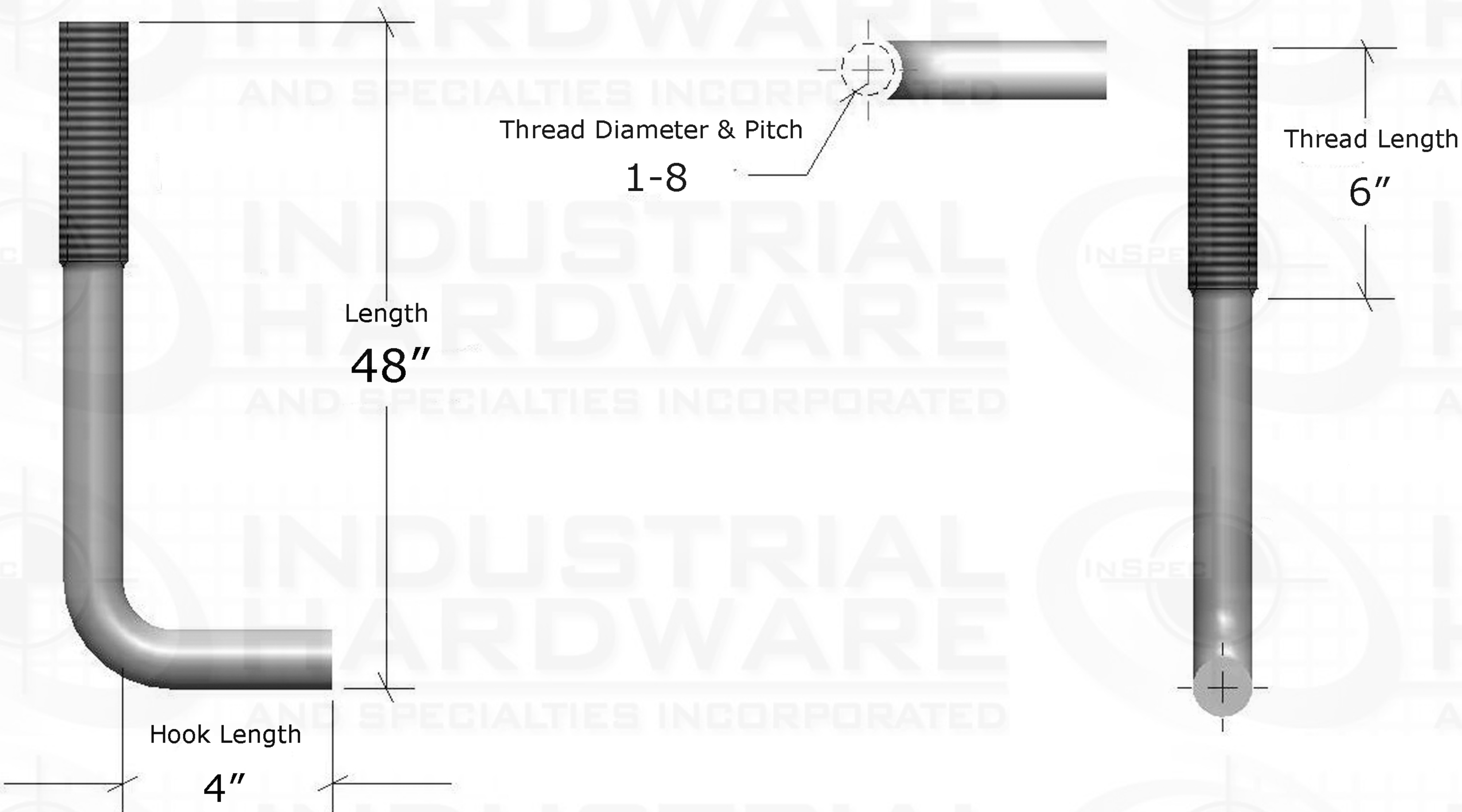

**PROPRIETARY AND CONFIDENTIAL**

THIS DRAWING AND IT'S CONTENT IS THE SOLE PROPERTY OF INDUSTRIAL HARDWARE & SPECIALTIES,INC.. ANY REPRODUCTION IN PART OR AS A WHOLE WITHOUT THE WRITTEN PERMISSION OF INDUSTRIAL HARDWARE & SPECIALTIES,INC. IS STRICTLY PROHIBITED.

		DIMENSIONS ARE IN INCHES TOLERANCES: FRACTIONAL $\pm 1/64"$ ANGULAR: MACH $\pm 1^\circ$ BEND $\pm 1^\circ$ TWO PLACE DECIMAL $\pm .01"$ THREE PLACE DECIMAL $\pm .005"$ CONCENTRICITY T.I.R. = $.005"$		NAME	DATE
		MATERIAL FINISH ASTM F1554-Grade 55 Hot Dip Galvanized			
NEXT ASSY	USED ON	PART NUMBER <b>121-10.48.040.06VG</b>			
APPLICATION		DO NOT SCALE DRAWING			
			DRAWN		
			CHECKED		
			ENG APPR.		
			MFG APPR.		
			Q.A.		
			COMMENTS:		

**INDUSTRIAL HARDWARE AND SPECIALTIES INCORPORATED**

17-B KENTUCKY AVENUE  
PATERSON, NEW JERSEY 07503  
TEL: 973-684-4010 FAX: 973-684-3095  
email: TechSupport@industrialhardware.com  
www.industrialhardware.com

SIZE	DWG. NO.	REV.
<b>A</b>		

SCALE: 1:8    WEIGHT: 9.66 lbs ea    SHEET 1 OF 1