

| REVISIONS | | DATE | APPROVED |
|-----------|------|-------------|----------|
| ZONE | REV. | DESCRIPTION | |
| | | | |
| | | | |

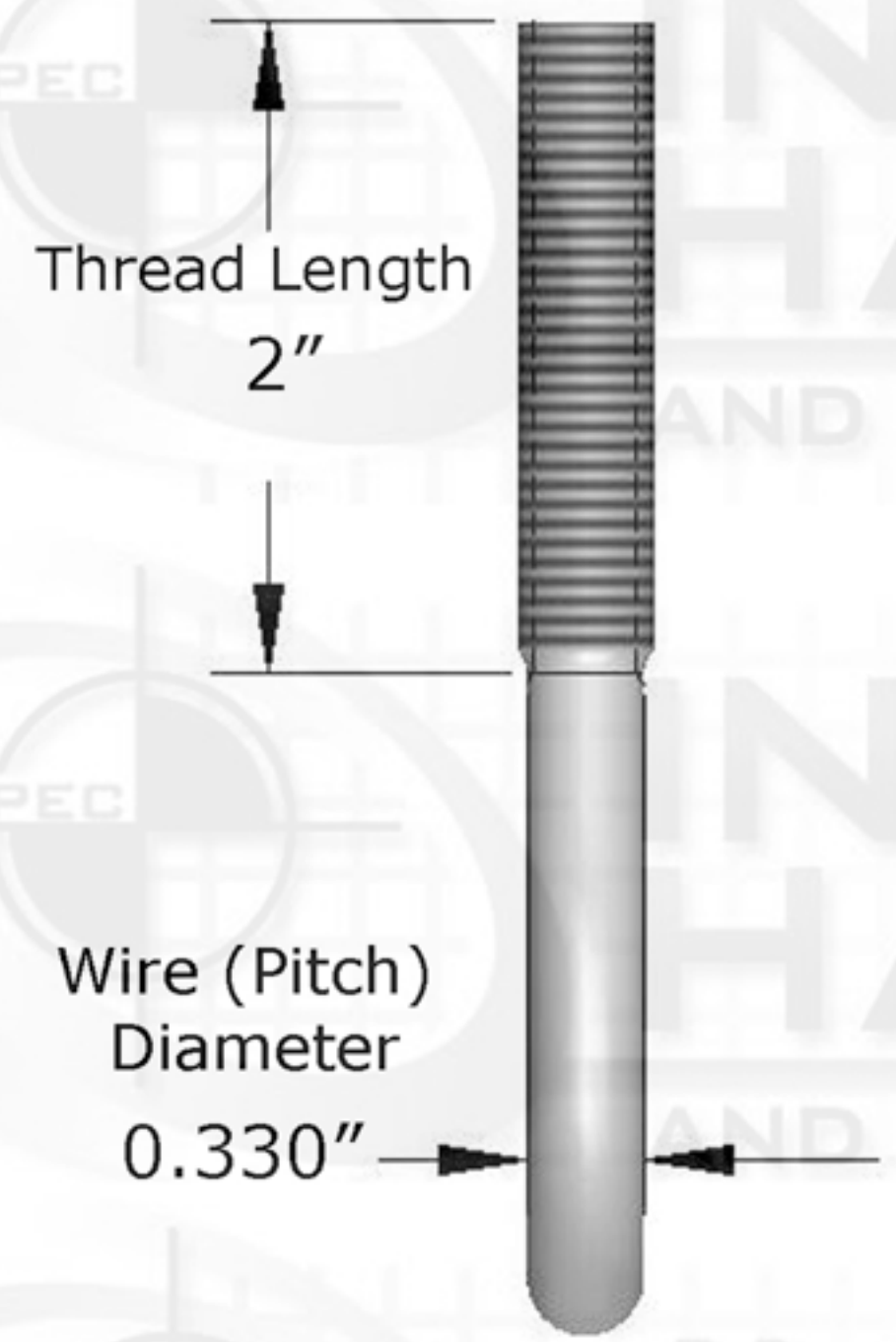
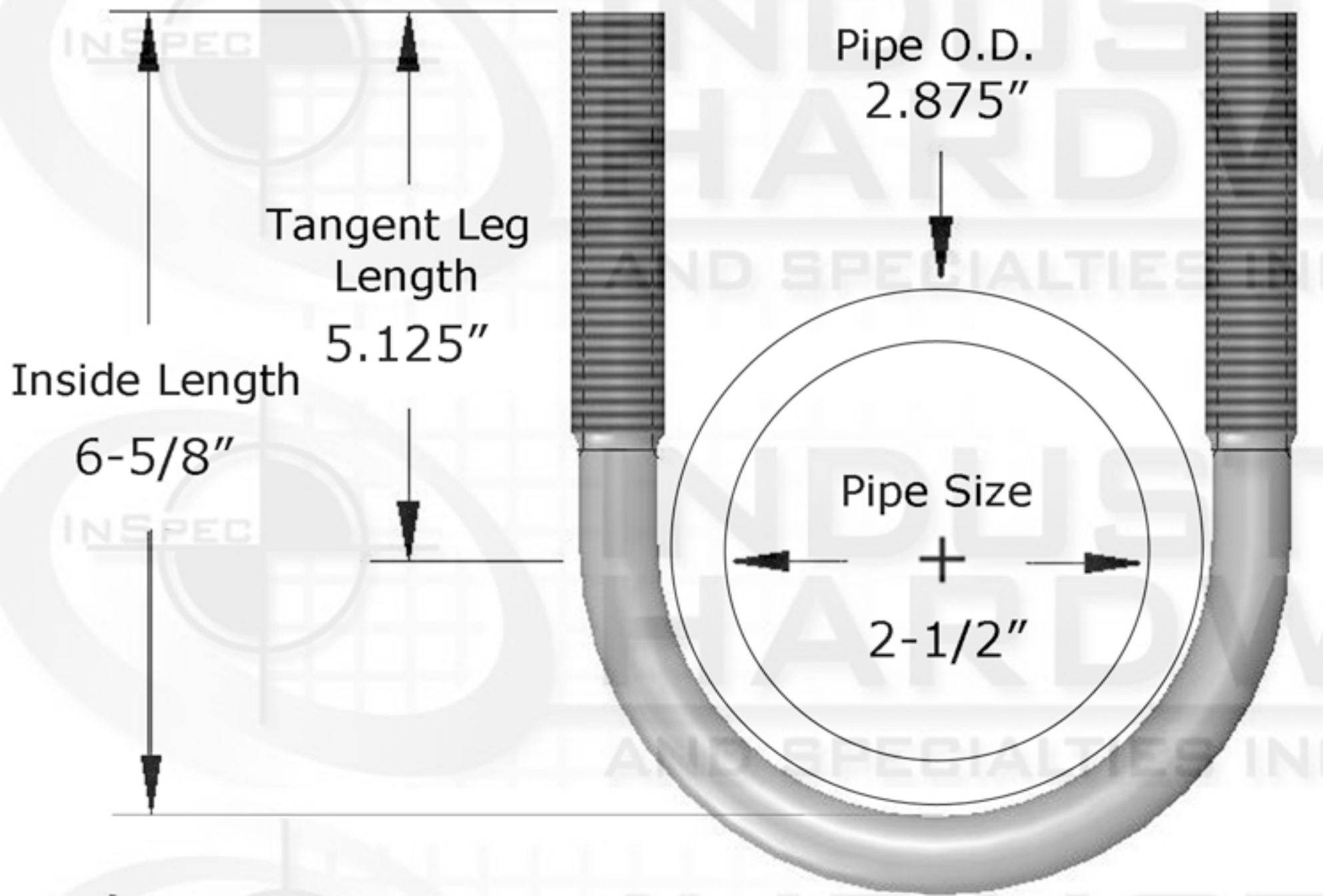
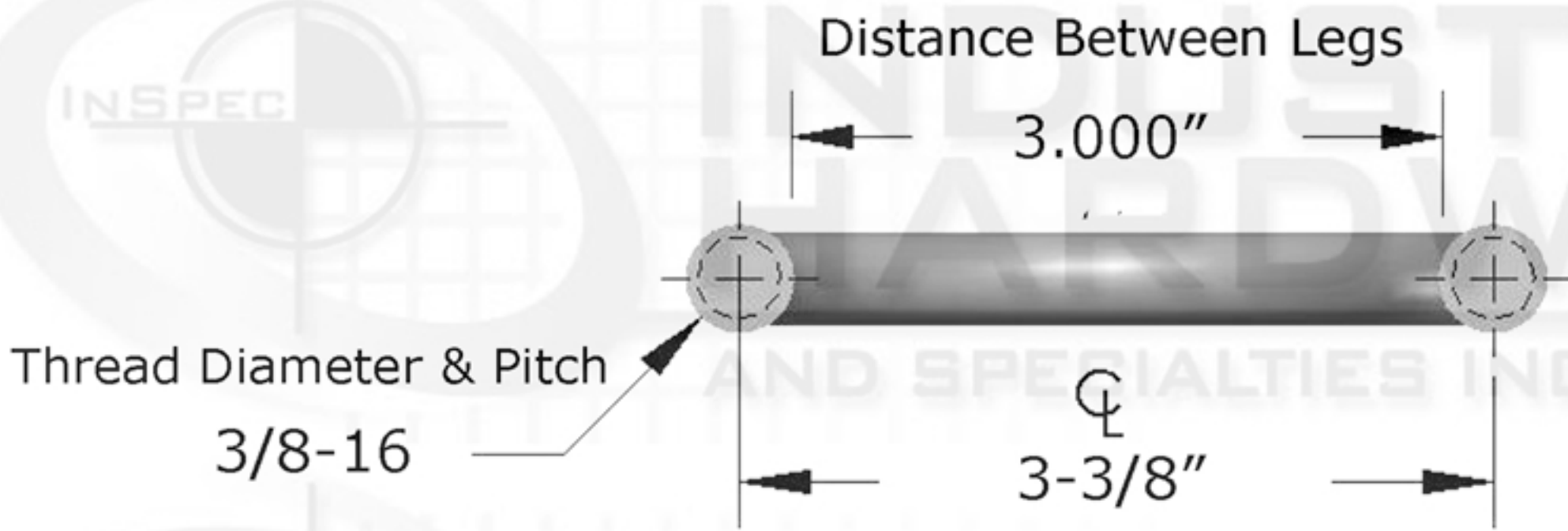

PROPRIETARY AND CONFIDENTIAL

THIS DRAWING AND IT'S CONTENT IS THE SOLE PROPERTY OF INDUSTRIAL HARDWARE & SPECIALTIES,INC.. ANY REPRODUCTION IN PART OR AS A WHOLE WITHOUT THE WRITTEN PERMISSION OF INDUSTRIAL HARDWARE & SPECIALTIES,INC. IS STRICTLY PROHIBITED.

| | | | |
|--|---------|-----------|------|
| DIMENSIONS ARE IN INCHES TOLERANCES: FRACTIONAL ± 1/64" ANGULAR: MACH ± 1° BEND ± 1° TWO PLACE DECIMAL ± .01" THREE PLACE DECIMAL ± .005" CONCENTRICITY T.I.R. = .005" | | NAME | DATE |
| NEXT ASSY | USED ON | DRAWN | |
| APPLICATION | | CHECKED | |
| DO NOT SCALE DRAWING | | ENG APPR. | |
| | | MFG APPR. | |
| | | Q.A. | |
| | | COMMENTS: | |

MATERIAL FINISH
Zinc Plated Steel

PART NUMBER
78A-UBH37-0250-Z



**17-B KENTUCKY AVENUE
PATERSON, NEW JERSEY 07503
TEL: 973-684-4010 FAX: 973-684-3095
email: TechSupport@industrialhardware.com
www.industrialhardware.com**

| | | |
|------------------|-------------|--------------|
| SIZE A | DWG. NO. | REV. |
| SCALE: 1:8 | WEIGHT: 0.4 | SHEET 1 OF 1 |