

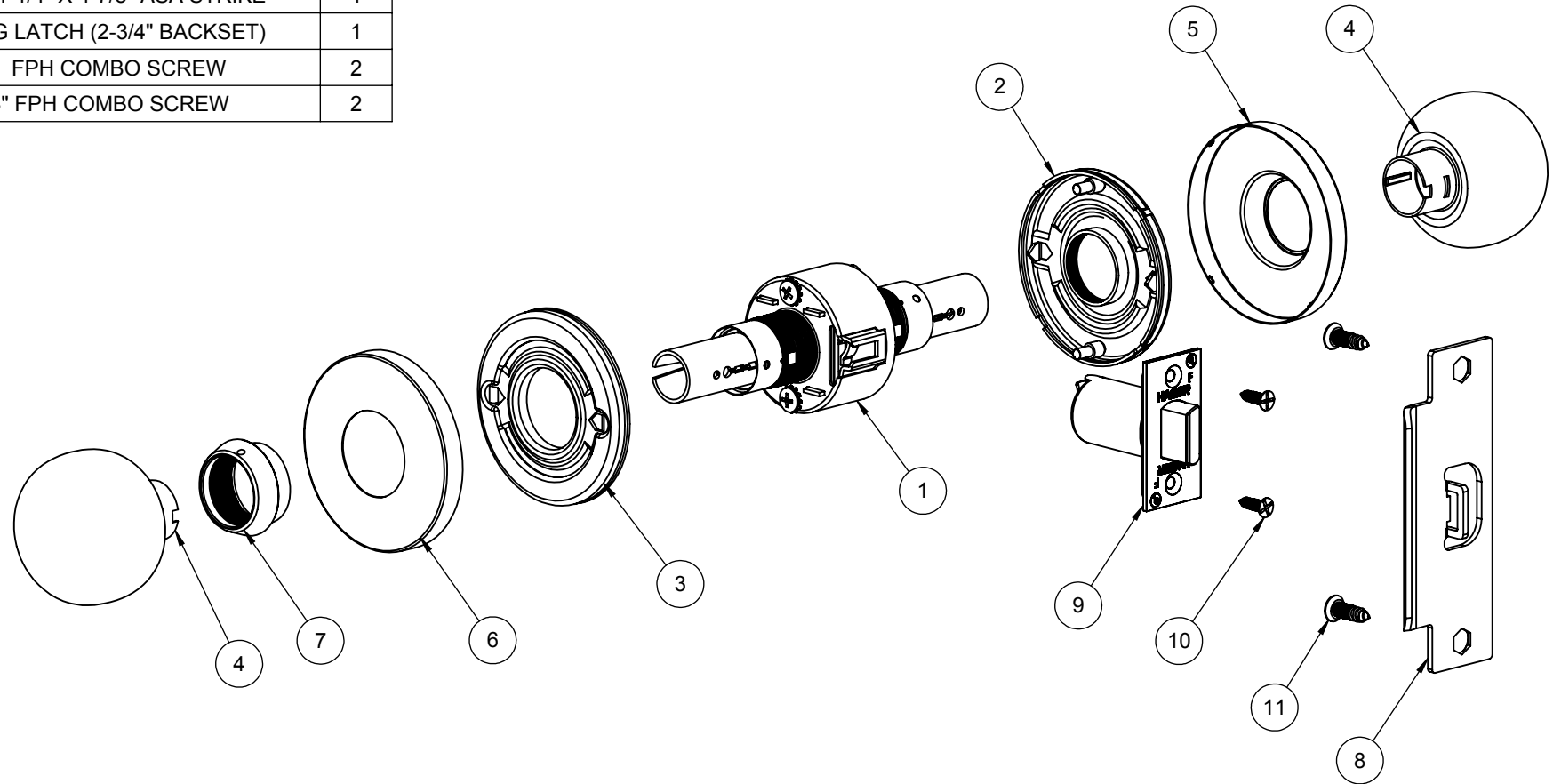

ITEM NO.	FILE NUMBER	DESCRIPTION	QTY.
1	S-LS00950	KNOBSET CHASSIS - 10 FUNCTION	1
2	S-LS00956	OUTSIDE ROSE LINER (KNOB)	1
3	S-LS00955	INSIDE ROSE LINER (KNOB)	1
4	S-LS00953	APOLLO PASSAGE KNOB	2
5	S-LS00952	OUTSIDE ROSE (KNOB)	1
6	S-LS00951	INSIDE ROSE (KNOB)	1
7	S-LS00943	THREADED COLLAR	1
8	S-LS00236	STANDARD 1-1/4" X 4-7/8" ASA STRIKE	1
9	S-LS00618	3943 SPRING LATCH (2-3/4" BACKSET)	1
10	S-LS00882	#8 X 3/4" FPH COMBO SCREW	2
11	S-LS00882	#12 X 3/4" FPH COMBO SCREW	2



 <p><b>PROPRIETARY &amp; CONFIDENTIAL</b> THE INFORMATION CONTAINED IN THIS DRAWING IS THE SOLE PROPERTY OF HAGER COMPANIES. ANY REPRODUCTION IN PART OR AS A WHOLE WITHOUT THE WRITTEN PERMISSION OF HAGER COMPANIES IS PROHIBITED.</p>	<p>HAGER RESERVES THE RIGHT TO MAKE DESIGN CHANGES WITHOUT NOTICE. CALL HAGER ENGINEERING AT 1-800-325-9995 FOR THE LATEST REVISION DATE OF TEMPLATE.</p>	<p>DRAWN MRJ 11/18/2010</p>	<p>3410 GRADE 1 - PASSAGE KNOBSET</p>		
		<p>ENG. APPR. - -</p>			
		<p>MATERIAL Material &lt;not specified&gt;</p>	<p>Q.A.</p>	<p>SIZE DWG. NO. <b>B</b> S-LS01043</p>	<p>REV. <b>01</b></p>
		<p>FINISH -</p>	<p>TOLERANCES: FRACTIONAL: ±0.015" ANGULAR: MACH: ±1° BEND: ±1° TWO PLACE DECIMAL: ±0.01" THREE PLACE DECIMAL: ±0.004"</p>	<p>SCALE: 1:4</p>	<p>WEIGHT: 1.15</p>
<p>DO NOT SCALE DRAWING</p>					