

ITEM NO.	FILE NUMBER	DESCRIPTION	QTY.
1	S-LS00950	KNOBSET CHASSIS - 80 FUNCTION	1
2	S-LS00956	OUTSIDE ROSE LINER (KNOB)	1
3	S-LS00955	INSIDE ROSE LINER (KNOB)	1
4	S-LS00954	APOLLO KNOB ENDCAP	1
5	S-LS00952	OUTSIDE ROSE (KNOB)	1
6	S-LS00951	INSIDE ROSE (KNOB)	1
7	S-LS00953	APOLLO PASSAGE KNOB	1
8	S-LS00943	THREADED COLLAR	1
9	S-LS00617	6-PIN DRILLED CYLINDER	1
9.2	S-LS00214	TAILPIECE (2-639-7002)	1
10	S-LS00236	STANDARD 1-1/4" X 4-7/8" ASA STRIKE	1
11	S-LS00882	#8 X 3/4" FPH COMBO SCREW	2
12	S-LS00882	#12 X 3/4" FPH COMBO SCREW	2
13	S-LS00608	3944 DEAD LATCH (2-3/4" BACKSET)	1
14	S-LS00953	APOLLO KEYED KNOB	1

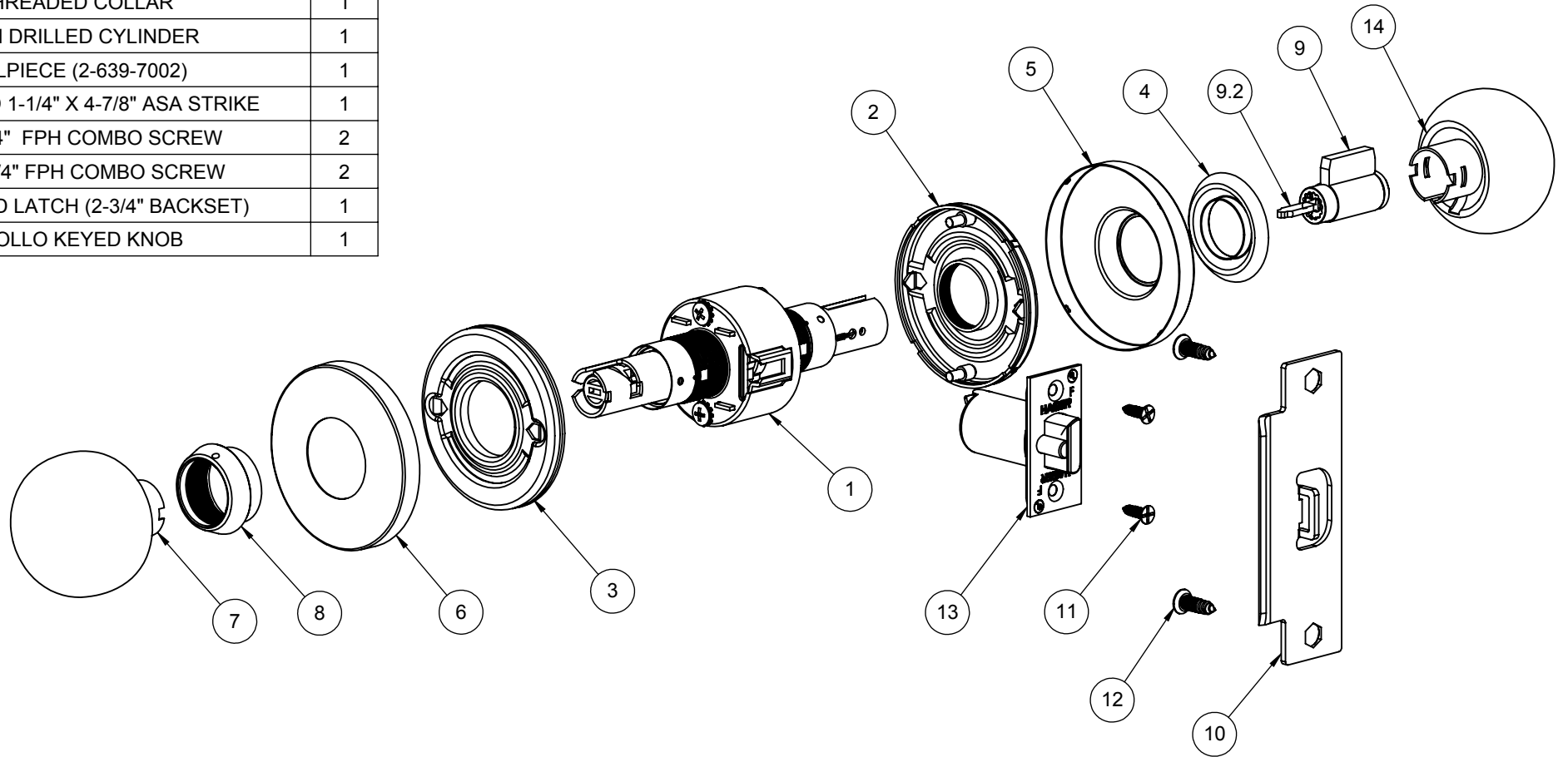

NOTE: (2) KEYS PROVIDED



PROPRIETARY & CONFIDENTIAL
 THE INFORMATION CONTAINED
 IN THIS DRAWING IS THE SOLE
 PROPERTY OF HAGER
 COMPANIES. ANY REPRODUCTION
 IN PART OR AS A WHOLE WITHOUT
 THE WRITTEN PERMISSION OF
 HAGER COMPANIES IS PROHIBITED.

HAGER RESERVES
 THE RIGHT TO
 MAKE DESIGN
 CHANGES
 WITHOUT NOTICE.
 CALL HAGER
 ENGINEERING AT
 1-800-325-9995
 FOR THE LATEST
 REVISION DATE
 OF TEMPLATE.

MATERIAL	Material <not specified>
FINISH	-
DO NOT SCALE DRAWING	

DRAWN	MRJ	11/18/2010
ENG. APPR.	-	-
TOLERANCES:		
FRACTIONAL: ±0.015"		
ANGULAR: MACH: ±1° BEND: ±1°		
TWO PLACE DECIMAL: ±0.01"		
THREE PLACE DECIMAL: ±0.004"		

3480		GRADE 1 - STOREROOM KNOBSET	
SIZE	DWG. NO.	REV.	
B	S-LS01048	02	
SCALE: 1:4	WEIGHT: 1.38	SHEET 1 OF 1	