

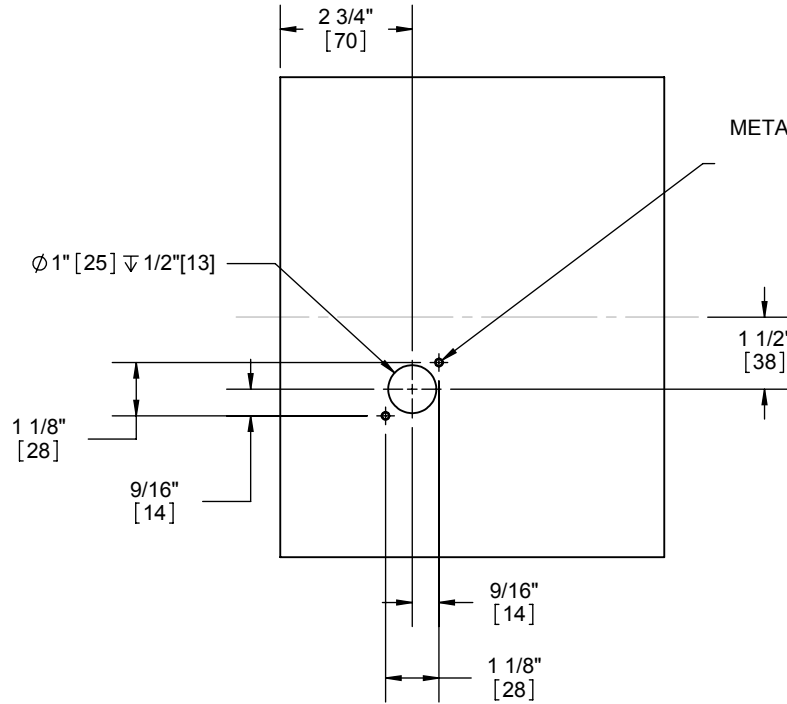

DOOR EDGE:
NO MODIFICATIONS
REQUIRED



METAL: DRILL/TAP FOR #8-32 MOUNTING SCREWS
 $\varnothing .136 \nabla .656$, $\square \varnothing .164 [4] \nabla .500$
 WOOD: PRE-DRILL $\varnothing 1/8$ " HOLES
 (2 PLACES)

OUTSIDE

(RH, RHR SECTIONAL SHOWN)

 <p>PROPRIETARY & CONFIDENTIAL THE INFORMATION CONTAINED IN THIS DRAWING IS THE SOLE PROPERTY OF HAGER COMPANIES. ANY REPRODUCTION IN PART OR AS A WHOLE WITHOUT THE WRITTEN PERMISSION OF HAGER COMPANIES IS PROHIBITED.</p>	<p>HAGER RESERVES THE RIGHT TO MAKE DESIGN CHANGES WITHOUT NOTICE. CALL HAGER ENGINEERING AT 1-800-325-9995 FOR THE LATEST REVISION DATE OF TEMPLATE.</p>	DRAWN	TJS	9/21/07	<p>3800 3800 SECTIONAL DOOR PREP, FUNCTIONS: 17</p>				
		ENG. APPR.	-	-					
		MATERIAL	-	Q.A.			SIZE	DWG. NO.	REV.
		FINISH	-	<p>TOLERANCES: FRACTIONAL: ± 0.015" ANGULAR: MACH: $\pm 1^\circ$ BEND: $\pm 1^\circ$ TWO PLACE DECIMAL: ± 0.01" THREE PLACE DECIMAL: ± 0.004"</p>			A	T-LS00771	04
DO NOT SCALE DRAWING					SCALE: 1:4	WEIGHT: -	SHEET 1 OF 14		

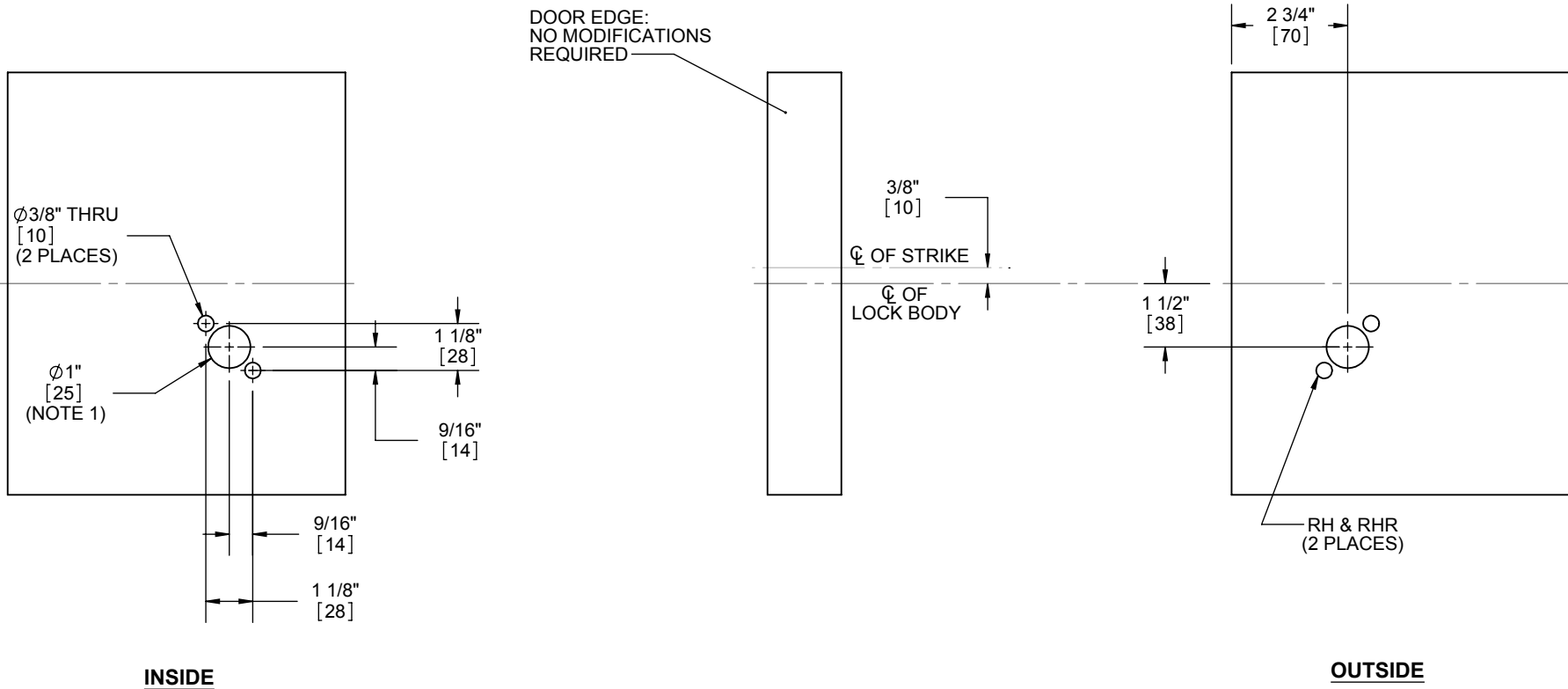

NOTES:

1. Although function 27 has dummy levers, the $\phi 1"$ thru hole is still required to accommodate the shape of the spring cages.

(RH, RHR SECTIONAL SHOWN)

 <p>PROPRIETARY & CONFIDENTIAL</p> <p>THE INFORMATION CONTAINED IN THIS DRAWING IS THE SOLE PROPERTY OF HAGER COMPANIES. ANY REPRODUCTION IN PART OR AS A WHOLE WITHOUT THE WRITTEN PERMISSION OF HAGER COMPANIES IS PROHIBITED.</p>	<p>HAGER RESERVES THE RIGHT TO MAKE DESIGN CHANGES WITHOUT NOTICE. CALL HAGER ENGINEERING AT 1-800-325-9995 FOR THE LATEST REVISION DATE OF TEMPLATE.</p>	DRAWN	TJS	9/21/07	<p>3800</p> <p>3800 SECTIONAL DOOR PREP, FUNCTIONS: 27</p>			
		ENG. APPR.	-	-				
		MATERIAL	Material <not specified>			Q.A.		
		FINISH	DO NOT SCALE DRAWING			<p>TOLERANCES:</p> <p>FRACTIONAL: $\pm 0.015"$</p> <p>ANGULAR: MACH: $\pm 1^\circ$ BEND: $\pm 1^\circ$</p> <p>TWO PLACE DECIMAL: $\pm 0.01"$</p> <p>THREE PLACE DECIMAL: $\pm 0.004"$</p>		
		SIZE	DWG. NO.		REV.			
		A	T-LS00771		04			
		SCALE: 1:4	WEIGHT: 5.02		SHEET 2 OF 14			

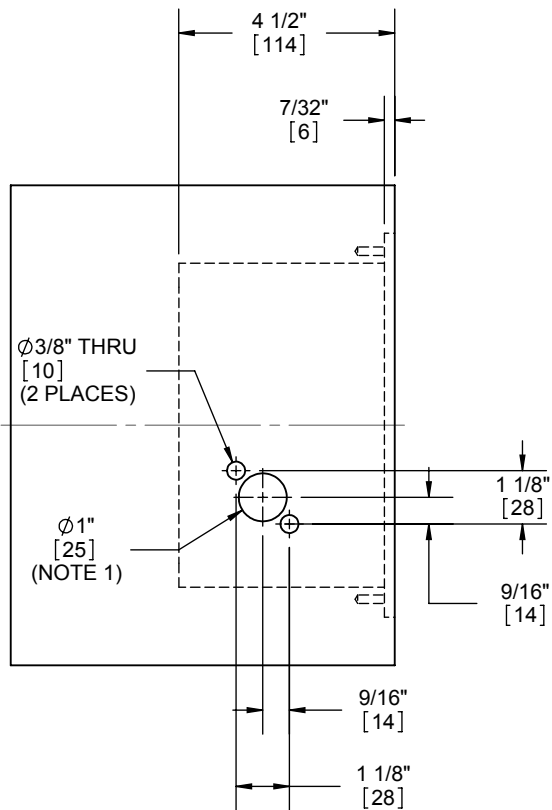

INSIDE

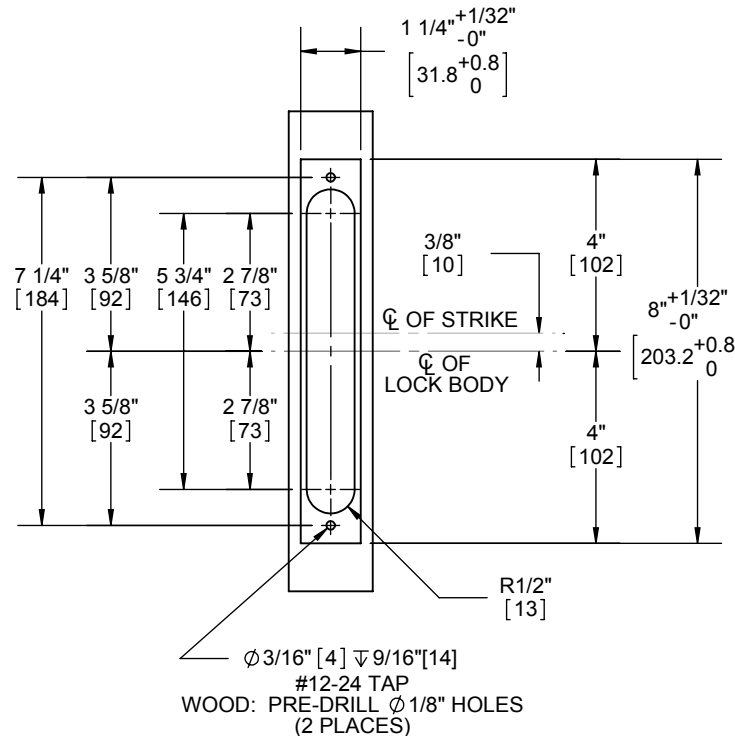

WOOD: PRE-DRILL Ø 1/8" HOLES (2 PLACES)
 #12-24 TAP
 Ø 3/16" [4] ∇ 9/16" [14]

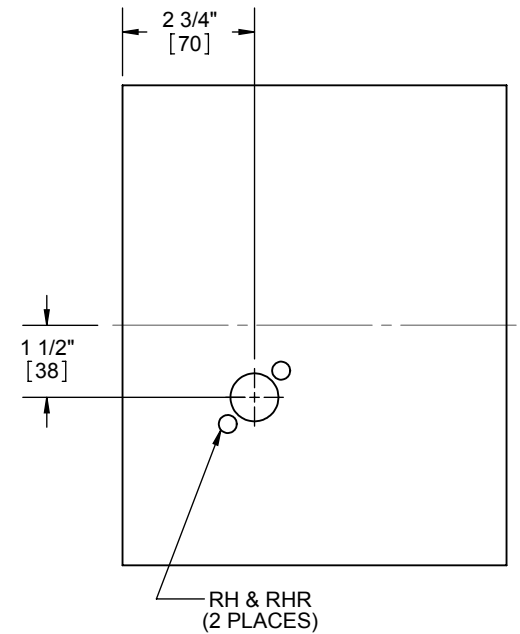

OUTSIDE

NOTES:

- Although function 77 (Double Dummy with Lock Case) has dummy levers, the Ø 1" thru hole is still required to accommodate the shape of the spring cages.

(RH, RHR SECTIONAL SHOWN)

 <p>PROPRIETARY & CONFIDENTIAL THE INFORMATION CONTAINED IN THIS DRAWING IS THE SOLE PROPERTY OF HAGER COMPANIES. ANY REPRODUCTION IN PART OR AS A WHOLE WITHOUT THE WRITTEN PERMISSION OF HAGER COMPANIES IS PROHIBITED.</p>	<p>HAGER RESERVES THE RIGHT TO MAKE DESIGN CHANGES WITHOUT NOTICE. CALL HAGER ENGINEERING AT 1-800-325-9995 FOR THE LATEST REVISION DATE OF TEMPLATE.</p>	<p>DRAWN TJS 9/21/07</p>	<p>3800</p>		
		<p>ENG. APPR. - -</p>	<p>3800 SECTIONAL DOOR PREP, FUNCTIONS: 10, 77</p>		
		<p>MATERIAL -</p>	<p>Q.A.</p>	<p>TOLERANCES: FRACTIONAL: ±0.015" ANGULAR: MACH: ± 1° BEND: ±1° TWO PLACE DECIMAL: ±0.01" THREE PLACE DECIMAL: ±0.004"</p>	
		<p>FINISH -</p>	<p>DO NOT SCALE DRAWING</p>		
<p>SIZE DWG. NO. T-LS00771</p>		<p>SCALE: 1:4</p>	<p>WEIGHT: -</p>	<p>REV. 04</p>	
<p>ST. LOUIS, MISSOURI</p>		<p>SHEET 3 OF 14</p>			

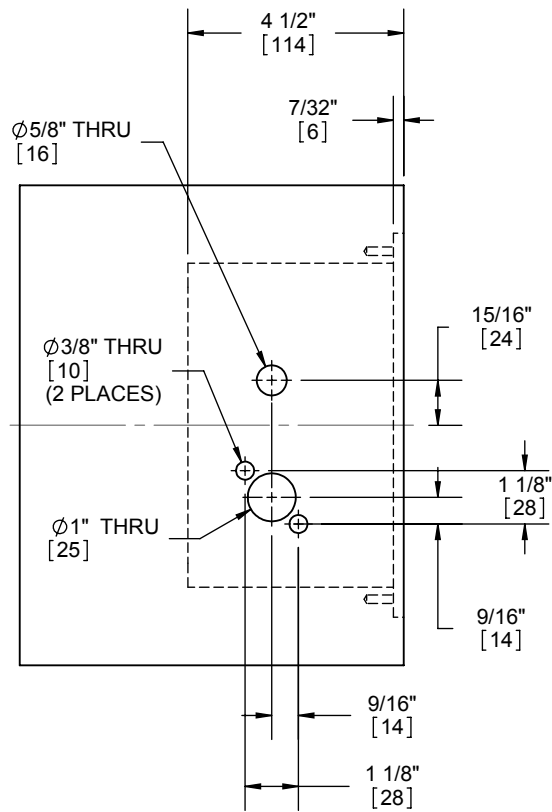

INSIDE

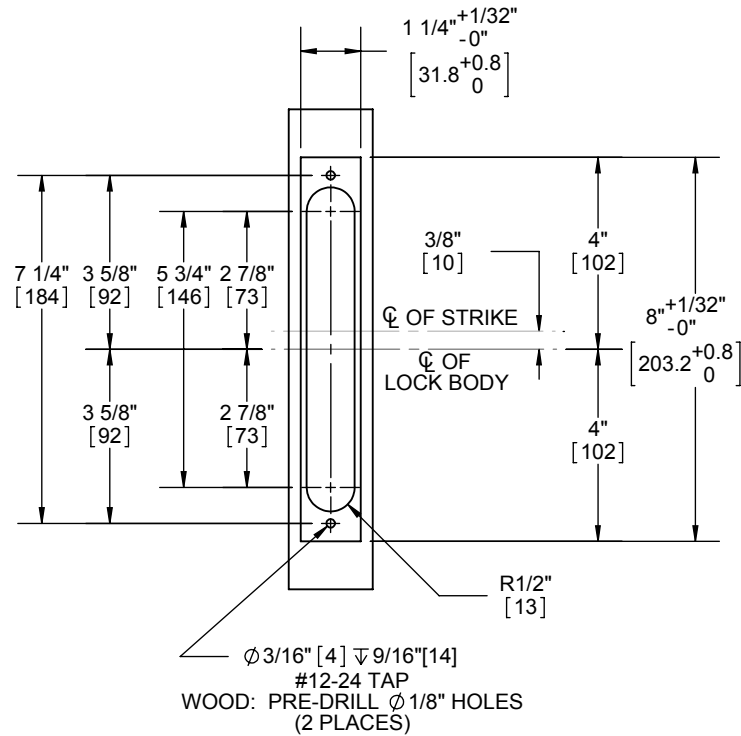

WOOD: PRE-DRILL Ø 1/8" HOLES (2 PLACES)

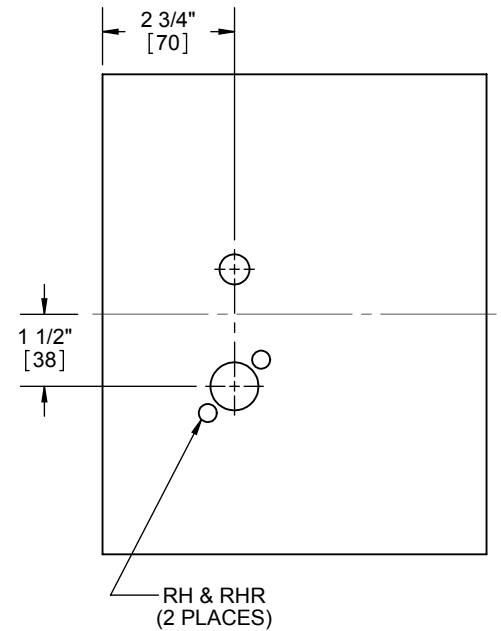

OUTSIDE

(RH, RHR SECTIONAL SHOWN)



PROPRIETARY & CONFIDENTIAL
 THE INFORMATION CONTAINED IN THIS DRAWING IS THE SOLE PROPERTY OF HAGER COMPANIES. ANY REPRODUCTION IN PART OR AS A WHOLE WITHOUT THE WRITTEN PERMISSION OF HAGER COMPANIES IS PROHIBITED.

HAGER RESERVES THE RIGHT TO MAKE DESIGN CHANGES WITHOUT NOTICE. CALL HAGER ENGINEERING AT 1-800-325-9995 FOR THE LATEST REVISION DATE OF TEMPLATE.

	DRAWN	TJS	9/21/07
	ENG. APPR.	-	-
MATERIAL	Q.A.		
FINISH	-		
DO NOT SCALE DRAWING	TOLERANCES: FRACTIONAL: ±0.015" ANGULAR: MACH: ± 1° BEND: ±1° TWO PLACE DECIMAL: ±0.01" THREE PLACE DECIMAL: ±0.004"		

3800		REV. 04	
3800 SECTIONAL DOOR PREP, FUNCTIONS: 40, 41, 44, 45, 96		T-LS00771	
SIZE A	DWG. NO.	SHEET 4 OF 14	
SCALE: 1:4	WEIGHT: -		

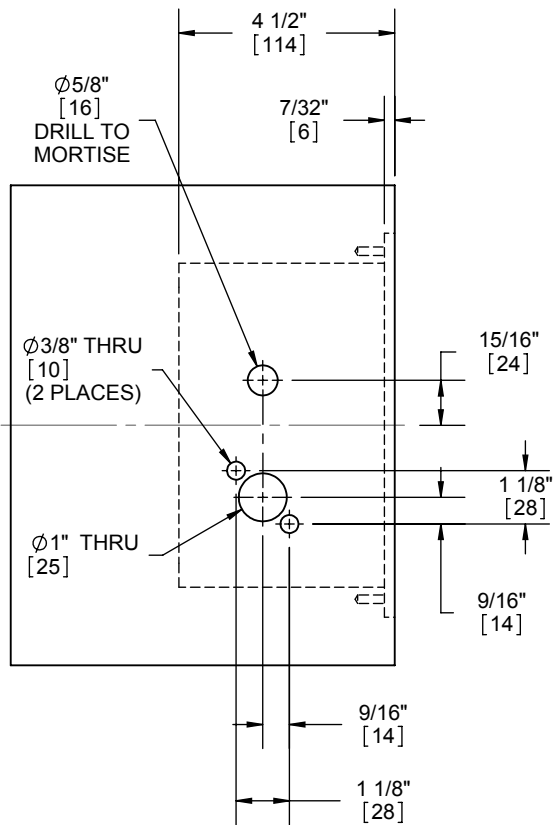

INSIDE

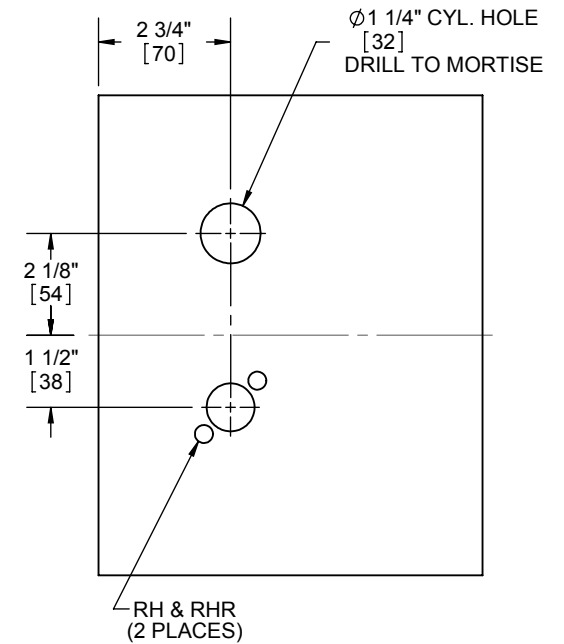
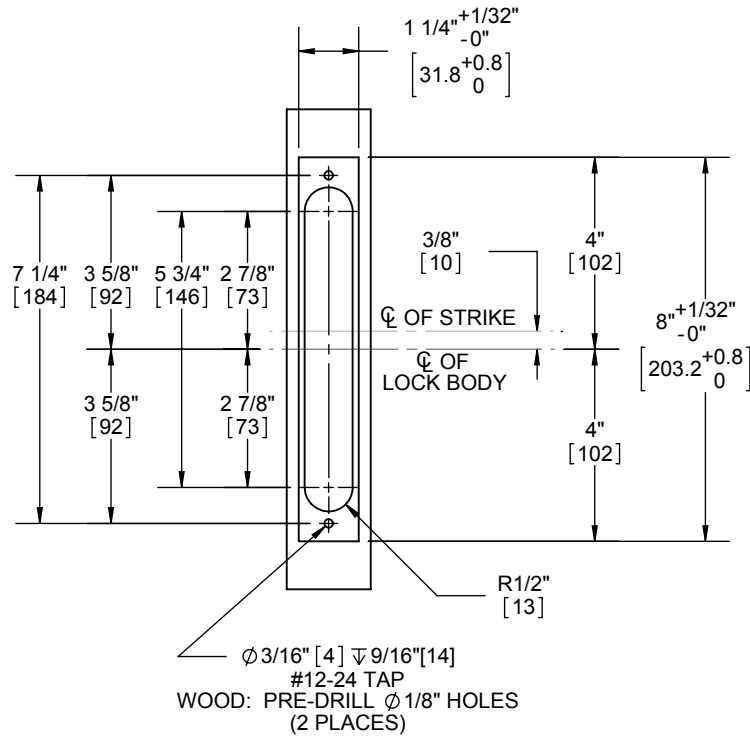

OUTSIDE

(RH, RHR SECTIONAL SHOWN)



PROPRIETARY & CONFIDENTIAL
 THE INFORMATION CONTAINED IN THIS DRAWING IS THE SOLE PROPERTY OF HAGER COMPANIES. ANY REPRODUCTION IN PART OR AS A WHOLE WITHOUT THE WRITTEN PERMISSION OF HAGER COMPANIES IS PROHIBITED.

HAGER RESERVES THE RIGHT TO MAKE DESIGN CHANGES WITHOUT NOTICE. CALL HAGER ENGINEERING AT 1-800-325-9995 FOR THE LATEST REVISION DATE OF TEMPLATE.

MATERIAL	-
FINISH	-
DO NOT SCALE DRAWING	

DRAWN	TJS	9/21/07
ENG. APPR.	-	-
Q.A.		
TOLERANCES: FRACTIONAL: $\pm 0.015"$ ANGULAR: MACH: $\pm 1^\circ$ BEND: $\pm 1^\circ$ TWO PLACE DECIMAL: $\pm 0.01"$ THREE PLACE DECIMAL: $\pm 0.004"$		

3800		REV.
3800 SECTIONAL DOOR PREP, FUNCTIONS: 50, 53, 56, 73, 81		04
SIZE	DWG. NO.	
A	T-LS00771	
SCALE: 1:4	WEIGHT: -	SHEET 5 OF 14

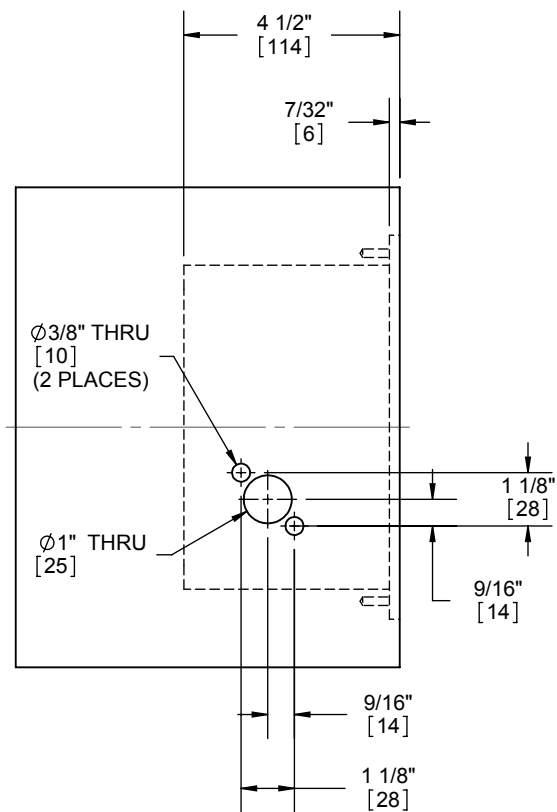

INSIDE

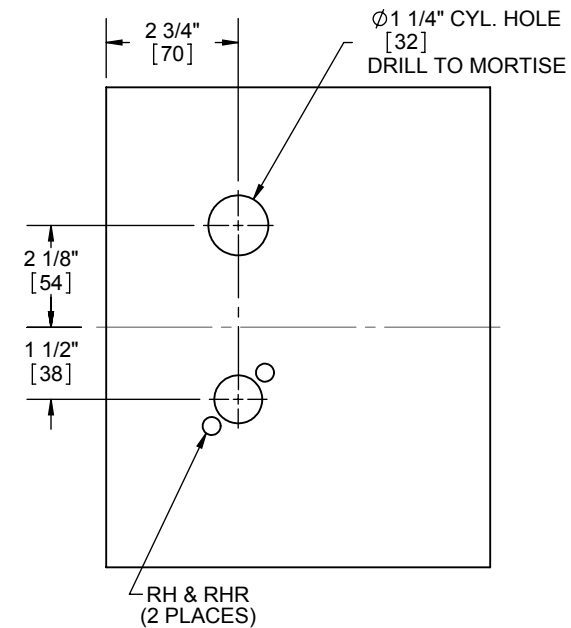
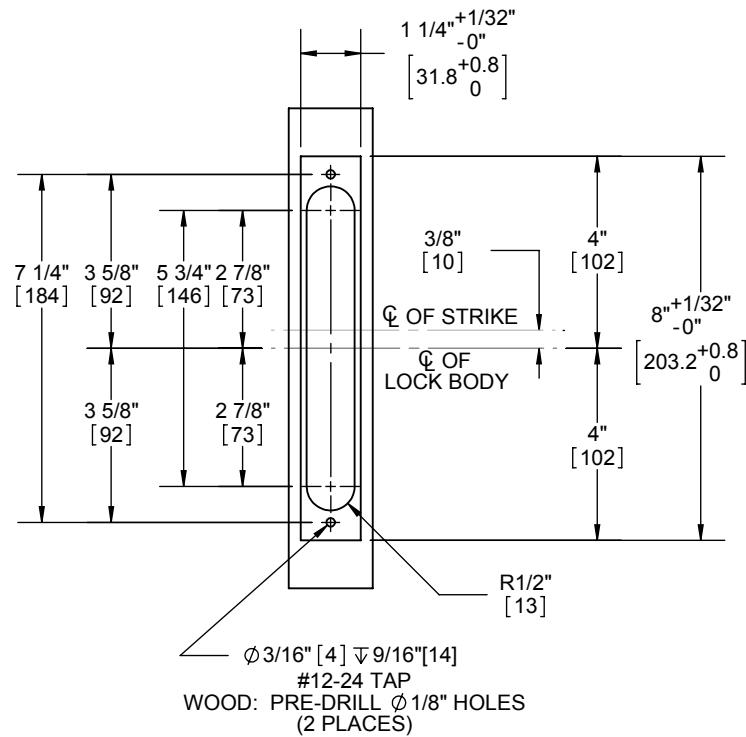

OUTSIDE

(RH, RHR SECTIONAL SHOWN)



PROPRIETARY & CONFIDENTIAL
THE INFORMATION CONTAINED IN THIS DRAWING IS THE SOLE PROPERTY OF HAGER COMPANIES. ANY REPRODUCTION IN PART OR AS A WHOLE WITHOUT THE WRITTEN PERMISSION OF HAGER COMPANIES IS PROHIBITED.

HAGER RESERVES THE RIGHT TO MAKE DESIGN CHANGES WITHOUT NOTICE. CALL HAGER ENGINEERING AT 1-800-325-9995 FOR THE LATEST REVISION DATE OF TEMPLATE.

	DRAWN	TJS	9/21/07
	ENG. APPR.	-	-
MATERIAL	Q.A.		
FINISH	-		
DO NOT SCALE DRAWING	TOLERANCES: FRACTIONAL: ±0.015" ANGULAR: MACH: ±1° BEND: ±1° TWO PLACE DECIMAL: ±0.01" THREE PLACE DECIMAL: ±0.004"		

3800		3800 SECTIONAL DOOR PREP, FUNCTIONS: 65, 70, 76, 80	
SIZE	DWG. NO.	REV.	
A	T-LS00771	04	
SCALE: 1:4	WEIGHT: -	SHEET 6 OF 14	

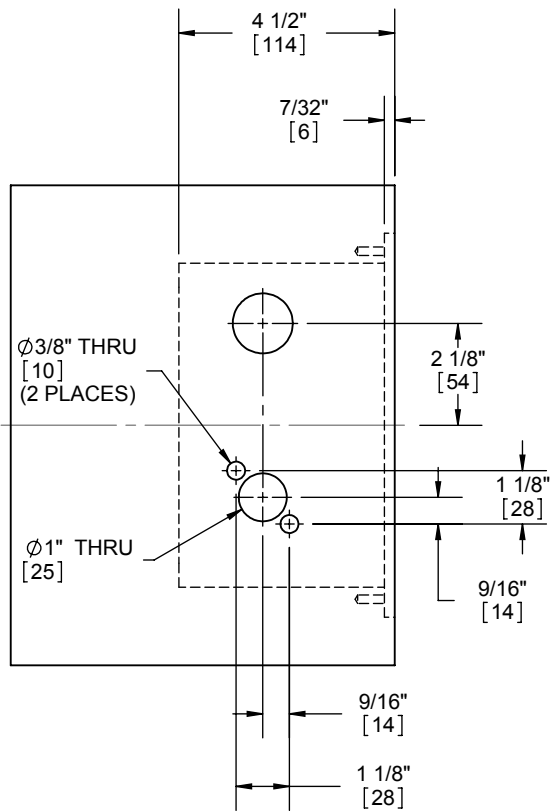

INSIDE

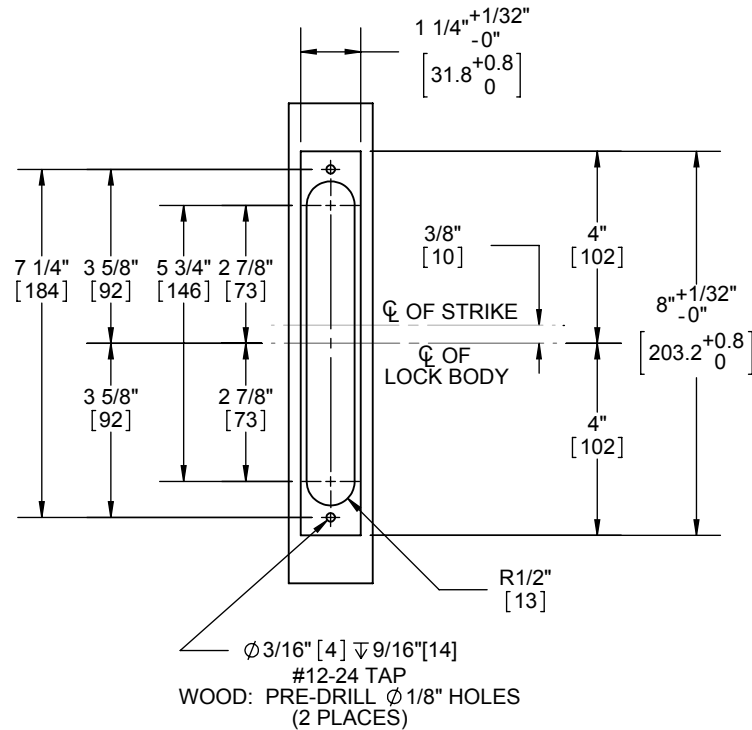

#12-24 TAP
WOOD: PRE-DRILL $\phi 1/8"$ HOLES
(2 PLACES)

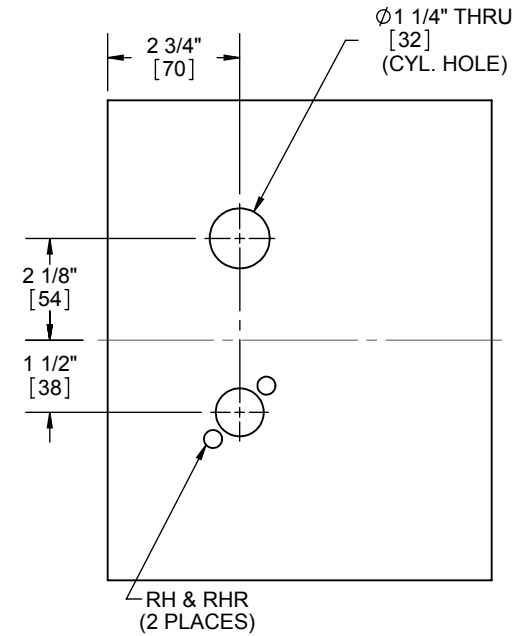

OUTSIDE

(RH, RHR SECTIONAL SHOWN)



PROPRIETARY & CONFIDENTIAL
THE INFORMATION CONTAINED IN THIS DRAWING IS THE SOLE PROPERTY OF HAGER COMPANIES. ANY REPRODUCTION IN PART OR AS A WHOLE WITHOUT THE WRITTEN PERMISSION OF HAGER COMPANIES IS PROHIBITED.

HAGER RESERVES THE RIGHT TO MAKE DESIGN CHANGES WITHOUT NOTICE. CALL HAGER ENGINEERING AT 1-800-325-9995 FOR THE LATEST REVISION DATE OF TEMPLATE.

MATERIAL	-
FINISH	-
DO NOT SCALE DRAWING	

DRAWN	TJS	9/21/07
ENG. APPR.	-	-
Q.A.		
TOLERANCES:		
FRACTIONAL: $\pm 0.015"$		
ANGULAR: MACH: $\pm 1^\circ$ BEND: $\pm 1^\circ$		
TWO PLACE DECIMAL: $\pm 0.01"$		
THREE PLACE DECIMAL: $\pm 0.004"$		

3800		REV.
3800 SECTIONAL DOOR PREP, FUNCTIONS: 57, 61, 66, 82, 83		04
SIZE	DWG. NO.	
A	T-LS00771	
SCALE: 1:4	WEIGHT: -	SHEET 7 OF 14

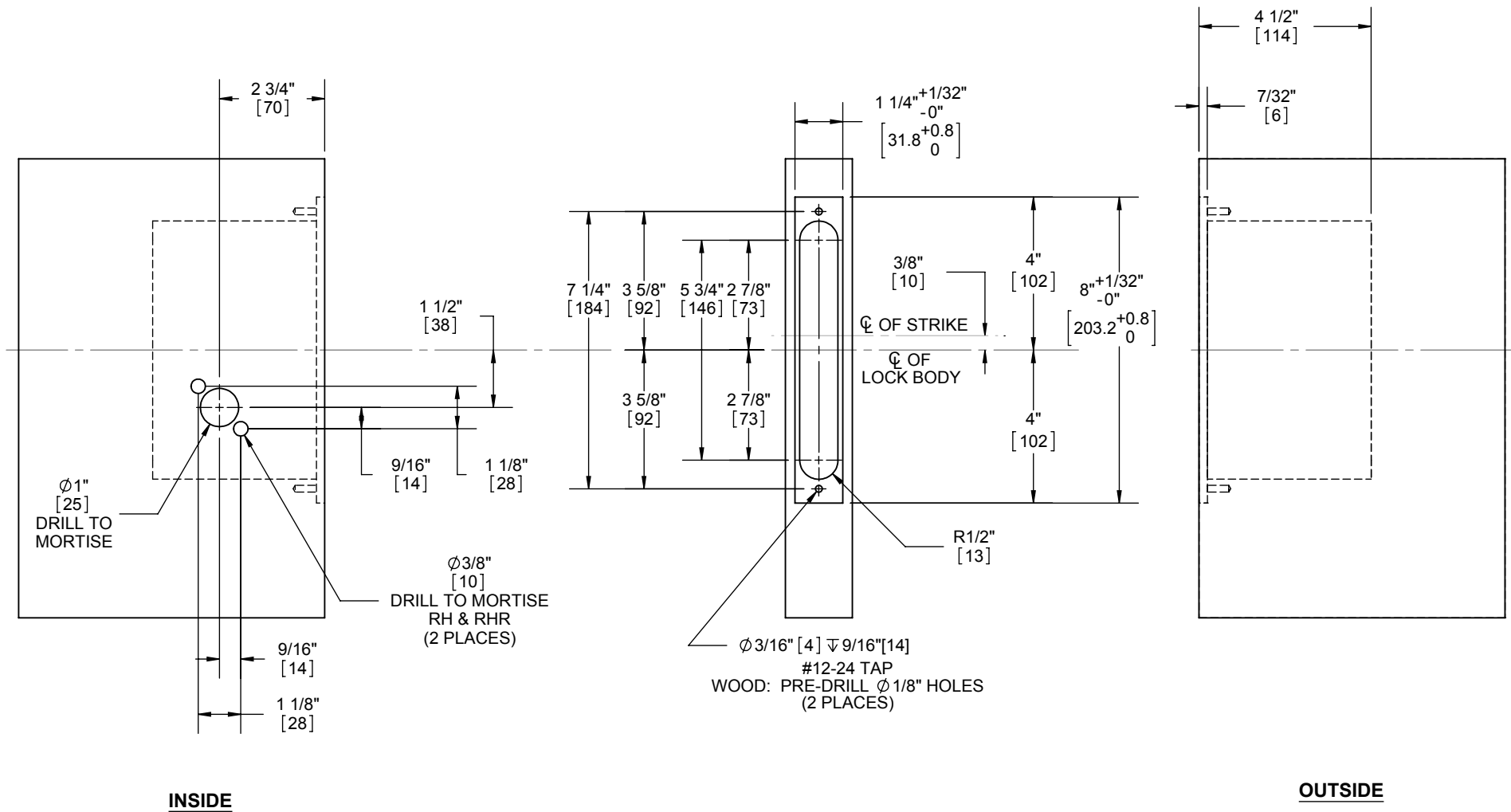

(RH, RHR SECTIONAL SHOWN)



PROPRIETARY & CONFIDENTIAL

THE INFORMATION CONTAINED IN THIS DRAWING IS THE SOLE PROPERTY OF HAGER COMPANIES. ANY REPRODUCTION IN PART OR AS A WHOLE WITHOUT THE WRITTEN PERMISSION OF HAGER COMPANIES IS PROHIBITED.

HAGER RESERVES THE RIGHT TO MAKE DESIGN CHANGES WITHOUT NOTICE. CALL HAGER ENGINEERING AT 1-800-325-9995 FOR THE LATEST REVISION DATE OF TEMPLATE.

DRAWN	TJS	9/21/07
ENG. APPR.	-	-
MATERIAL	Material <not specified>	
FINISH		
DO NOT SCALE DRAWING		
TOLERANCES: FRACTIONAL: ±0.015" ANGULAR: MACH: ± 1° BEND: ±1° TWO PLACE DECIMAL: ±0.01" THREE PLACE DECIMAL: ±0.004"		

3800
3800 SECTIONAL DOOR PREP,
FUNCTION: 25

SIZE	DWG. NO.	REV.
A	T-LS00771	04
SCALE: 1:4	WEIGHT: 4.96	SHEET 8 OF 14

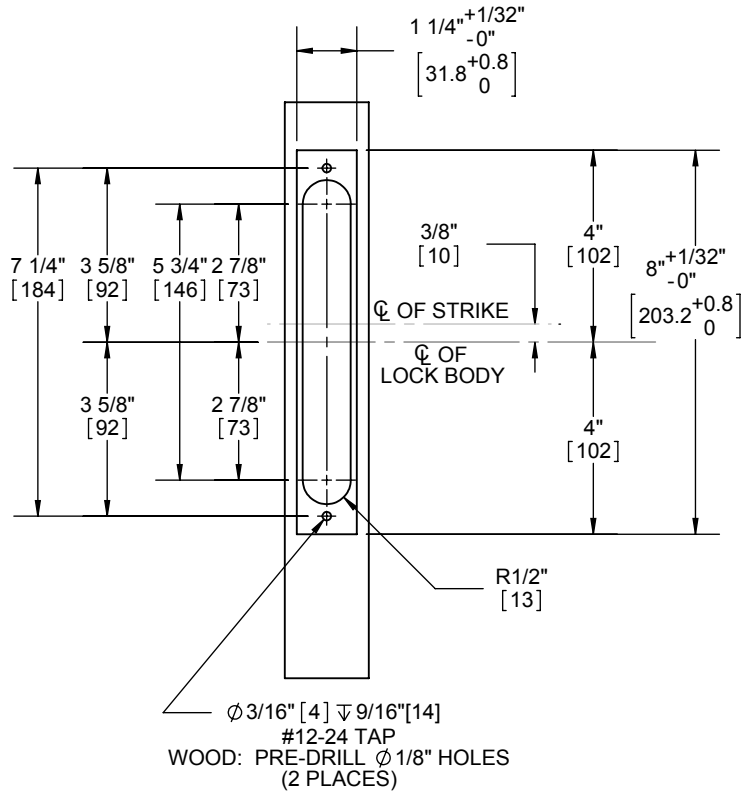
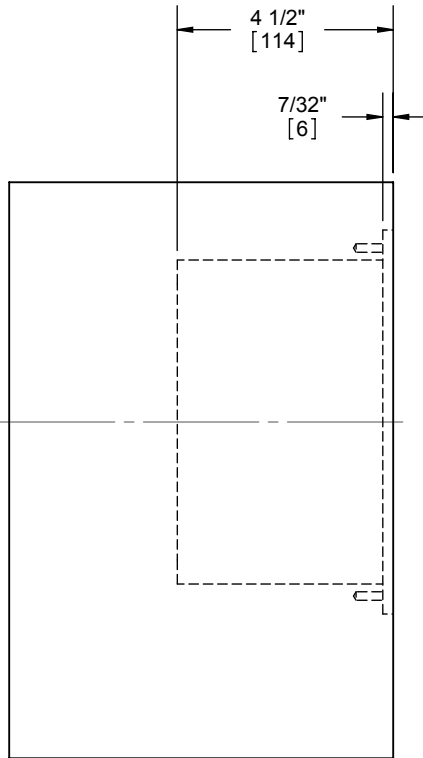

INSIDE

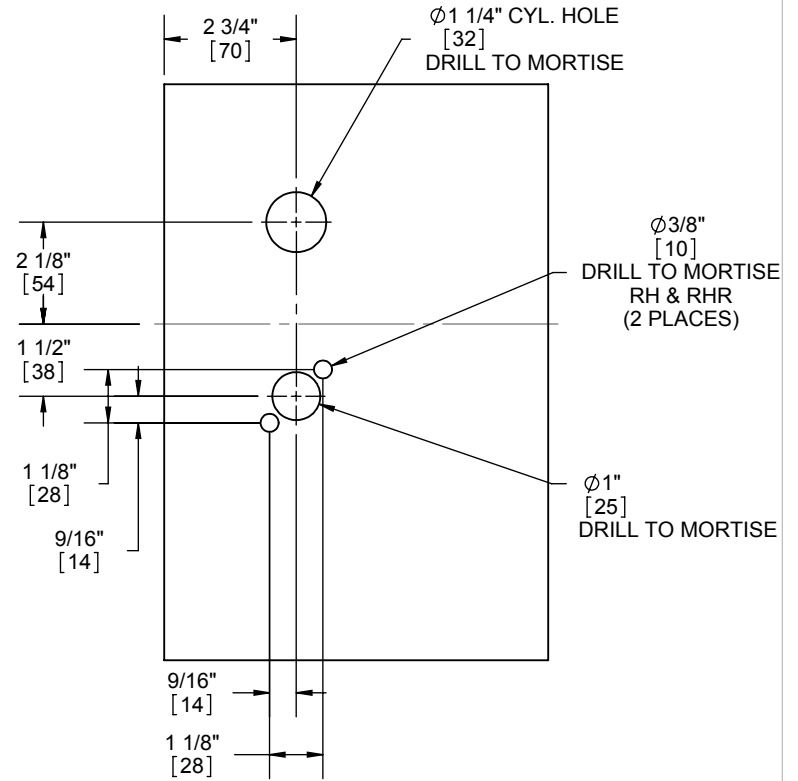

OUTSIDE

(RH, RHR SECTIONAL SHOWN)



PROPRIETARY & CONFIDENTIAL
THE INFORMATION CONTAINED IN THIS DRAWING IS THE SOLE PROPERTY OF HAGER COMPANIES. ANY REPRODUCTION IN PART OR AS A WHOLE WITHOUT THE WRITTEN PERMISSION OF HAGER COMPANIES IS PROHIBITED.

HAGER RESERVES THE RIGHT TO MAKE DESIGN CHANGES WITHOUT NOTICE. CALL HAGER ENGINEERING AT 1-800-325-9995 FOR THE LATEST REVISION DATE OF TEMPLATE.

DRAWN	TJS	7/28/10
ENG. APPR.	-	-
MATERIAL	Material <not specified>	
FINISH	DO NOT SCALE DRAWING	
TOLERANCES: FRACTIONAL: ±0.015" ANGULAR: MACH: ± 1° BEND: ±1° TWO PLACE DECIMAL: ±0.01" THREE PLACE DECIMAL: ±0.004"		

3800		REV.
3800 SECTIONAL DOOR PREP, FUNCTION: 80 LIT		04
SIZE	DWG. NO.	
A	T-LS00771	
SCALE: 1:4	WEIGHT: 4.95	SHEET 9 OF 14

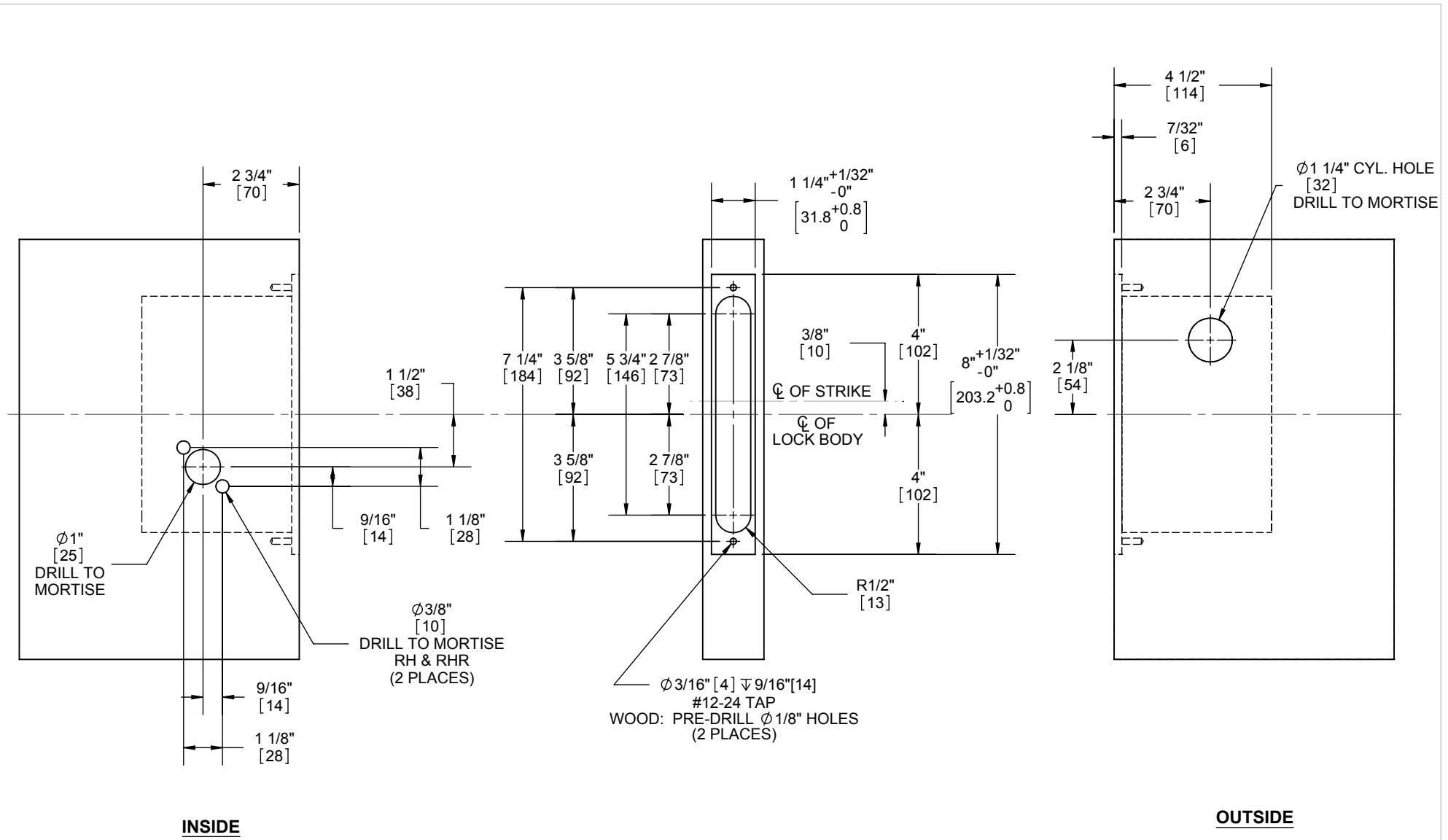

(RH, RHR SECTIONAL SHOWN)



PROPRIETARY & CONFIDENTIAL
 THE INFORMATION CONTAINED
 IN THIS DRAWING IS THE SOLE
 PROPERTY OF HAGER
 COMPANIES. ANY REPRODUCTION
 IN PART OR AS A WHOLE WITHOUT
 THE WRITTEN PERMISSION OF
 HAGER COMPANIES IS PROHIBITED.

HAGER RESERVES
 THE RIGHT TO
 MAKE DESIGN
 CHANGES
 WITHOUT NOTICE.
 CALL HAGER
 ENGINEERING AT
 1-800-325-9995
 FOR THE LATEST
 REVISION DATE
 OF TEMPLATE.

MATERIAL	Material <not specified>	
FINISH	DO NOT SCALE DRAWING	

DRAWN	TJS	9/21/07
ENG. APPR.	-	-
Q.A.		
TOLERANCES:		
FRACTIONAL: ±0.015"		
ANGULAR: MACH: ± 1° BEND: ± 1°		
TWO PLACE DECIMAL: ±0.01"		
THREE PLACE DECIMAL: ±0.004"		

3800		3800 SECTIONAL DOOR PREP, FUNCTION: 80 LOT	
SIZE	DWG. NO.	REV.	
A	T-LS00771	04	
SCALE: 1:4	WEIGHT: 4.95	SHEET 10 OF 14	

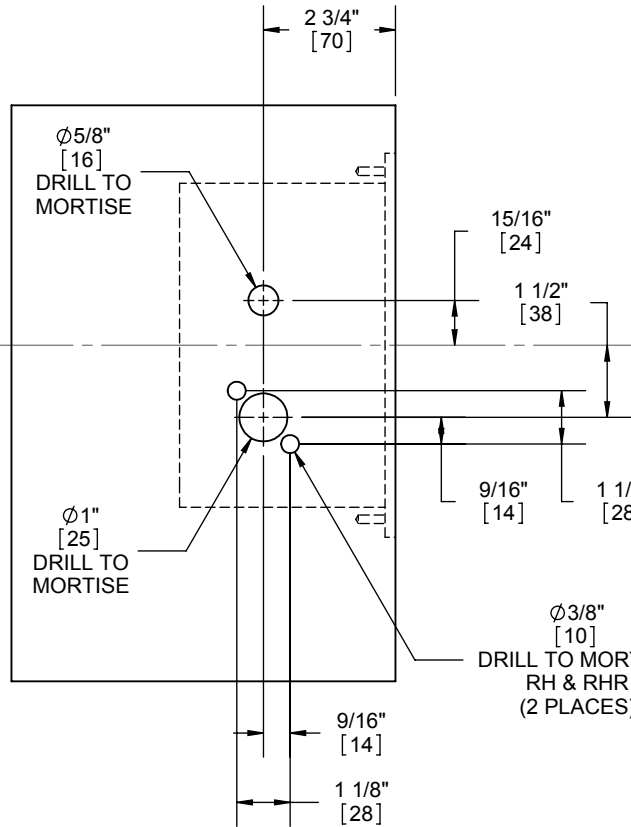

INSIDE

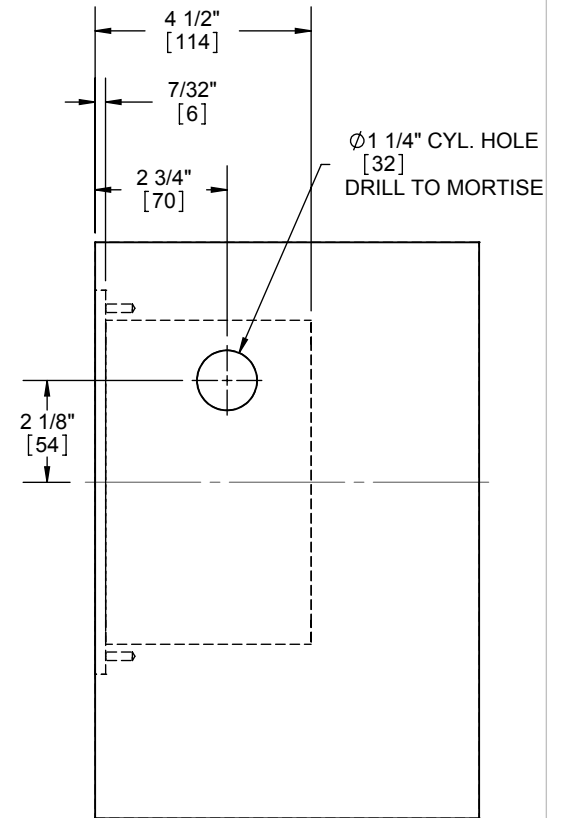
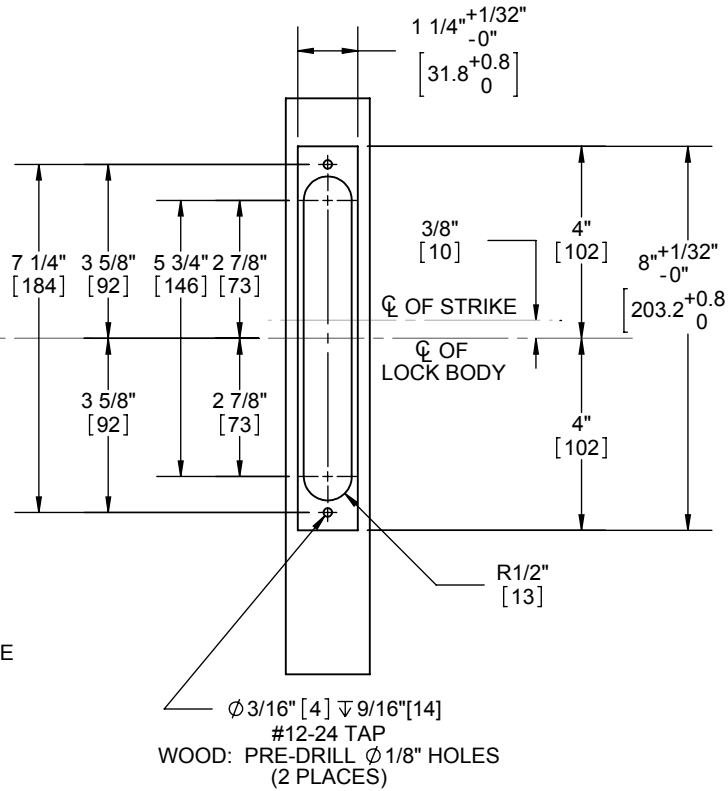

OUTSIDE

(RH, RHR SECTIONAL SHOWN)

 <p>PROPRIETARY & CONFIDENTIAL THE INFORMATION CONTAINED IN THIS DRAWING IS THE SOLE PROPERTY OF HAGER COMPANIES. ANY REPRODUCTION IN PART OR AS A WHOLE WITHOUT THE WRITTEN PERMISSION OF HAGER COMPANIES IS PROHIBITED.</p>	<p>HAGER RESERVES THE RIGHT TO MAKE DESIGN CHANGES WITHOUT NOTICE. CALL HAGER ENGINEERING AT 1-800-325-9995 FOR THE LATEST REVISION DATE OF TEMPLATE.</p>	DRAWN	TJS	9/21/07	<p>3800 3800 SECTIONAL DOOR PREP, FUNCTION: 81 LOT</p>			
		ENG. APPR.	-	-				
		MATERIAL	Material <not specified>			Q.A.		
		FINISH	DO NOT SCALE DRAWING			<p>TOLERANCES: FRACTIONAL: ±0.015" ANGULAR: MACH: ± 1° BEND: ±1° TWO PLACE DECIMAL: ±0.01" THREE PLACE DECIMAL: ±0.004"</p>		
		SIZE	DWG. NO.		REV.			
		A	T-LS00771		04			
		SCALE: 1:4	WEIGHT: 4.94		SHEET 11 OF 14			

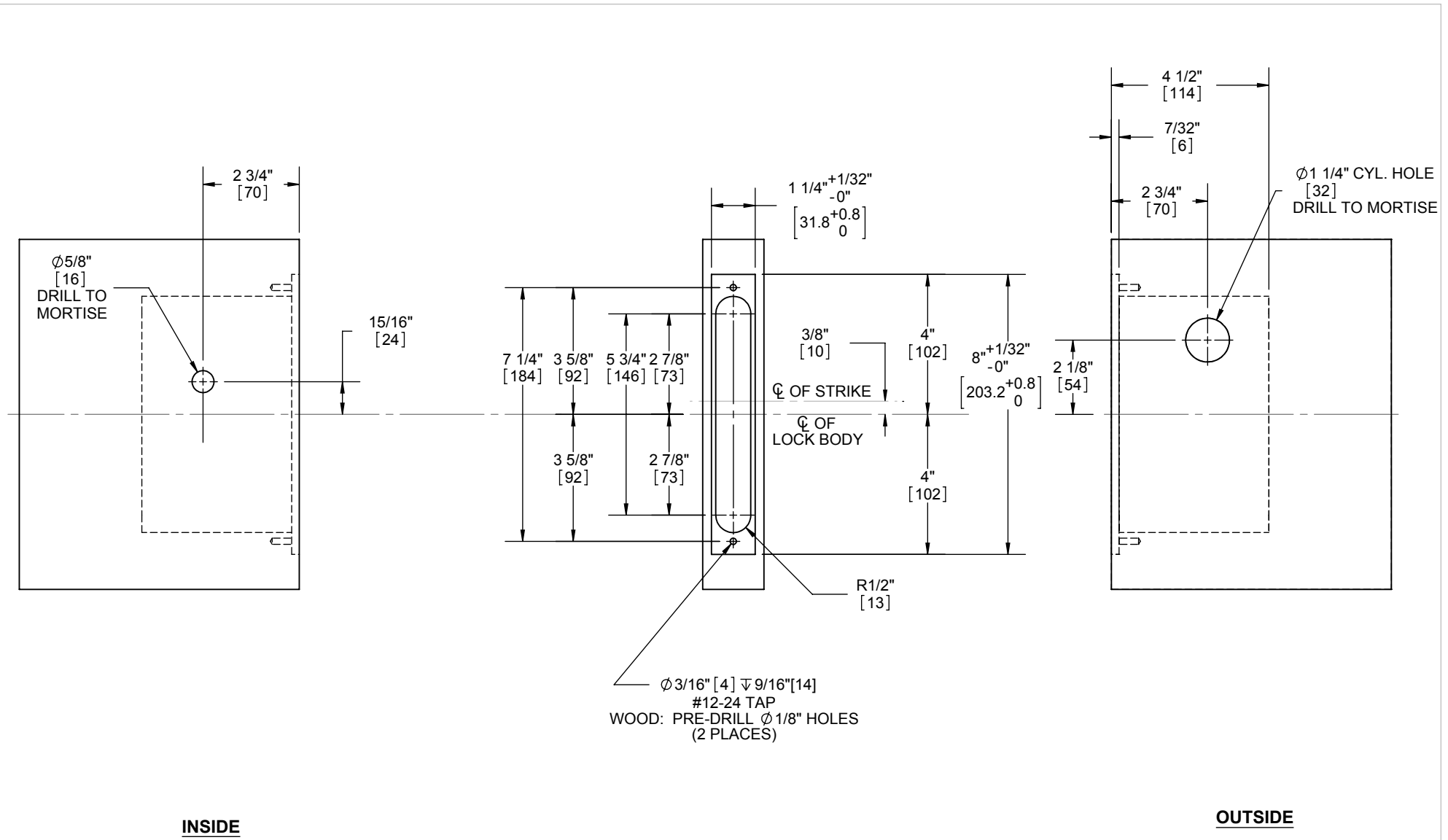

Ø 3/16" [4] ∇ 9/16" [14]
 #12-24 TAP
 WOOD: PRE-DRILL Ø 1/8" HOLES
 (2 PLACES)

INSIDE

OUTSIDE

(RH, RHR SHOWN)

 <p>PROPRIETARY & CONFIDENTIAL THE INFORMATION CONTAINED IN THIS DRAWING IS THE SOLE PROPERTY OF HAGER COMPANIES. ANY REPRODUCTION IN PART OR AS A WHOLE WITHOUT THE WRITTEN PERMISSION OF HAGER COMPANIES IS PROHIBITED.</p>	<p>HAGER RESERVES THE RIGHT TO MAKE DESIGN CHANGES WITHOUT NOTICE. CALL HAGER ENGINEERING AT 1-800-325-9995 FOR THE LATEST REVISION DATE OF TEMPLATE.</p>	DRAWN	TJS	9/21/07	<p>3800 3800 DOOR PREP, FUNCTION: 60</p>	
		ENG. APPR.	-	-		
		MATERIAL	Material <not specified>			<p>TOLERANCES: FRACTIONAL: ±0.015" ANGULAR: MACH: ± 1° BEND: ±1° TWO PLACE DECIMAL: ±0.01" THREE PLACE DECIMAL: ±0.004"</p>
		FINISH	DO NOT SCALE DRAWING			
<p>SIZE DWG. NO. A T-LS00771</p>		<p>SCALE: 1:4 WEIGHT: 3.95</p>		<p>REV. 04</p>	<p>SHEET 12 OF 14</p>	

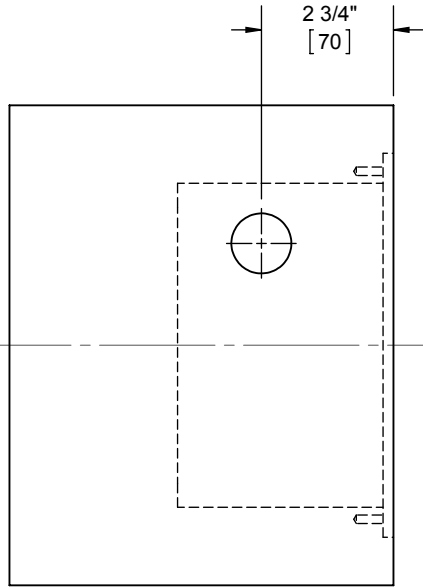

INSIDE

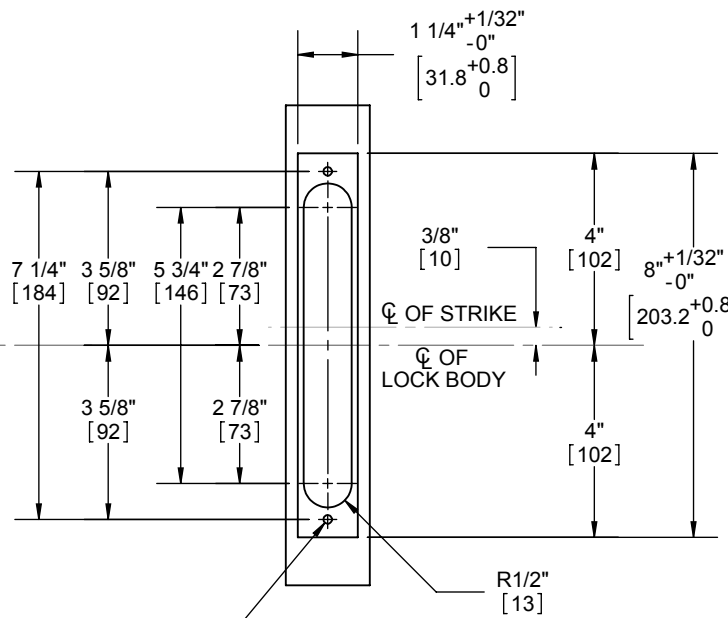

$\varnothing 3/16$ " [4] $\nabla 9/16$ " [14]
 #12-24 TAP
 WOOD: PRE-DRILL $\varnothing 1/8$ " HOLES
 (2 PLACES)

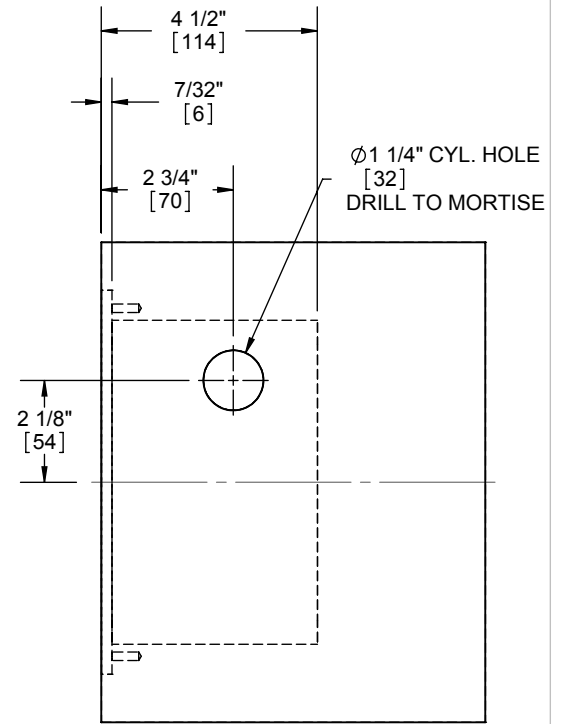

OUTSIDE

(RH, RHR SHOWN)

 PROPRIETARY & CONFIDENTIAL THE INFORMATION CONTAINED IN THIS DRAWING IS THE SOLE PROPERTY OF HAGER COMPANIES. ANY REPRODUCTION IN PART OR AS A WHOLE WITHOUT THE WRITTEN PERMISSION OF HAGER COMPANIES IS PROHIBITED.	HAGER RESERVES THE RIGHT TO MAKE DESIGN CHANGES WITHOUT NOTICE. CALL HAGER ENGINEERING AT 1-800-325-9995 FOR THE LATEST REVISION DATE OF TEMPLATE.	DRAWN	TJS	9/21/07	3800 3800 DOOR PREP, FUNCTIONS: 62, 63		
		MATERIAL	Material <not specified>			ENG. APPR.	-
		FINISH	DO NOT SCALE DRAWING			Q.A.	-
		TOLERANCES:				FRACTIONAL: ± 0.015 " ANGULAR: MACH: $\pm 1^\circ$ BEND: $\pm 1^\circ$ TWO PLACE DECIMAL: ± 0.01 " THREE PLACE DECIMAL: ± 0.004 "	
SIZE A DWG. NO. T-LS00771		SCALE: 1:4 WEIGHT: 3.93		REV. 04	SHEET 13 OF 14		

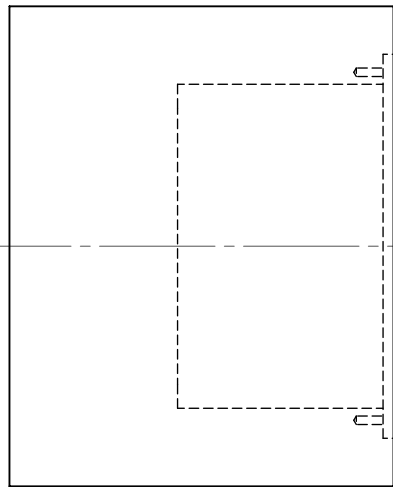

INSIDE

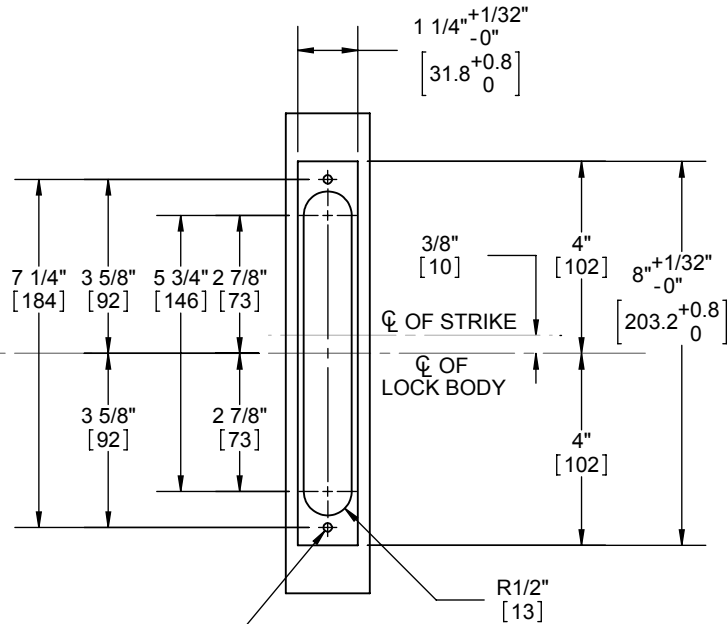

$\phi 3/16''$ [4] $\nabla 9/16''$ [14]
 #12-24 TAP
 WOOD: PRE-DRILL $\phi 1/8''$ HOLES
 (2 PLACES)

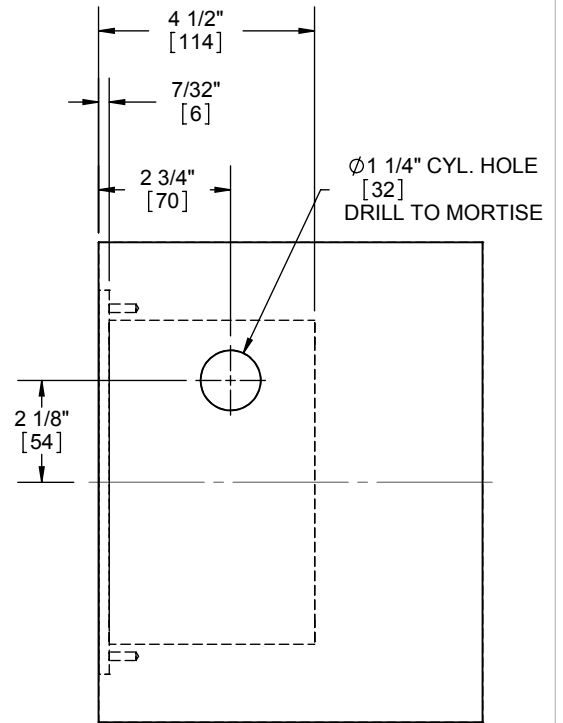

OUTSIDE

(RH, RHR SHOWN)

 PROPRIETARY & CONFIDENTIAL THE INFORMATION CONTAINED IN THIS DRAWING IS THE SOLE PROPERTY OF HAGER COMPANIES. ANY REPRODUCTION IN PART OR AS A WHOLE WITHOUT THE WRITTEN PERMISSION OF HAGER COMPANIES IS PROHIBITED.	HAGER RESERVES THE RIGHT TO MAKE DESIGN CHANGES WITHOUT NOTICE. CALL HAGER ENGINEERING AT 1-800-325-9995 FOR THE LATEST REVISION DATE OF TEMPLATE.	DRAWN TJS 9/21/07	3800 3800 DOOR PREP, FUNCTION: 64			
		ENG. APPR. - -				
		MATERIAL Material <not specified>	Q.A.	TOLERANCES: FRACTIONAL: $\pm 0.015''$ ANGULAR: MACH: $\pm 1^\circ$ BEND: $\pm 1^\circ$ TWO PLACE DECIMAL: $\pm 0.01''$ THREE PLACE DECIMAL: $\pm 0.004''$	SIZE DWG. NO.	REV.
		FINISH DO NOT SCALE DRAWING	A T-LS00771	04		
		SCALE: 1:4	WEIGHT: 3.95	SHEET 14 OF 14		