

CONTENTS	9611	9612	
1. TRACK (9821)	2	2	
2. CARRIER	4 (9824)	4 (9825)	
3. QUICK RELEASE PLATE(9610)	4	4	
4. FLOOR GUIDE (9115)	1	1	
5. #8 X 1-1/2" PPHS	5	5	
6. #8 X 3/4" PPHS	2	2	
7. #8 X 1" PPHS	8	8	
8. #8 X 5/8" TPHS	16	16	
9. SPACERS	2	2	
10. DOORSTOP (9880)	1	1	
(sold separately)			
11. PULL	2	2	
(Sold separately)			

1 PREPARE OPENING

OPENING HEIGHT MAX = DOOR HEIGHT + 3-3/16"
 OPENING HEIGHT MIN = DOOR HEIGHT + 2-9/16"

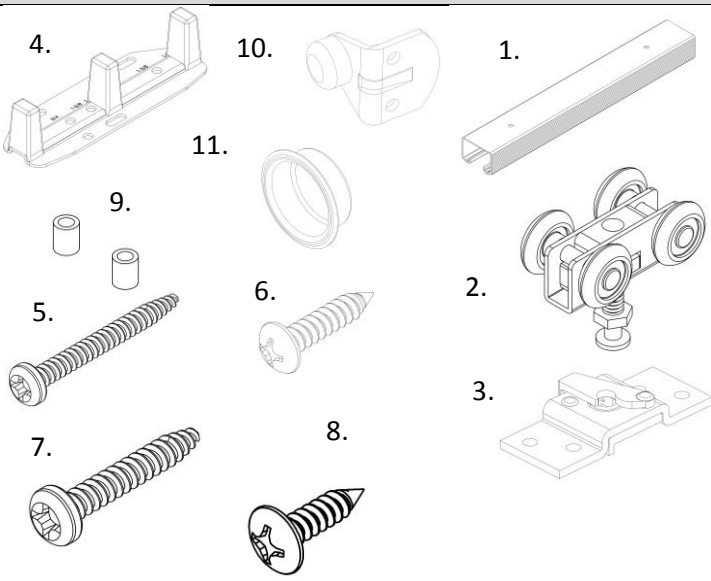
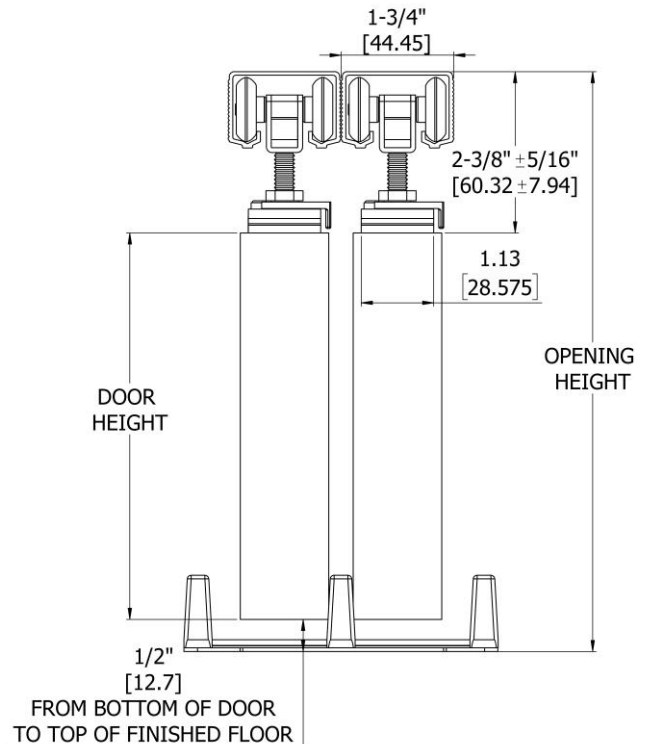
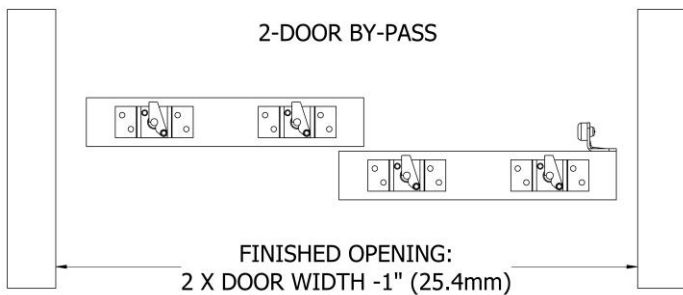

2 INSTALL TRACK AND HANGERS

- Center tracks in opening, flush for 1-3/8" doors, or with spacer kit for 1-3/4" doors. Secure with (#8 x 1") screws
- Leave a 1" gap between right end of track and door frame to allow for carrier removal
- Center quick release plates on door thickness
- Mount left plate edge 1" from near left door edge
- Mount right plate edge 2-3/4" from near right door edge
- Secure Carriers onto door with (#8 x 1") screws

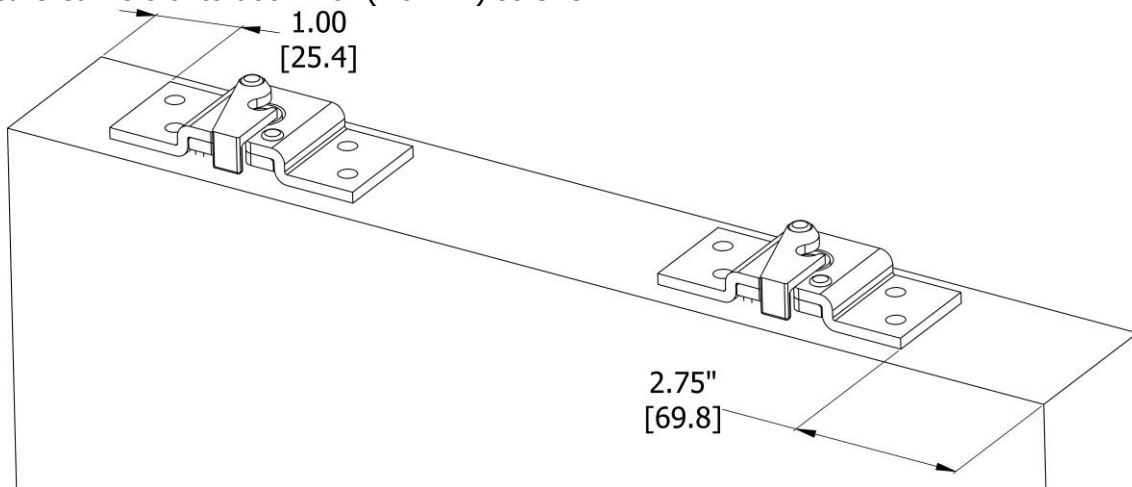
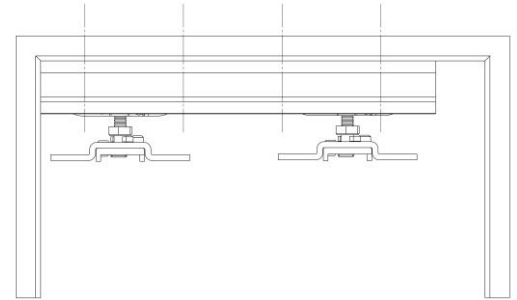

3 HANG DOORS

- Open quick release latches on brackets
- Slide door onto carrier and close hatch
- Repeat for front door on front rail

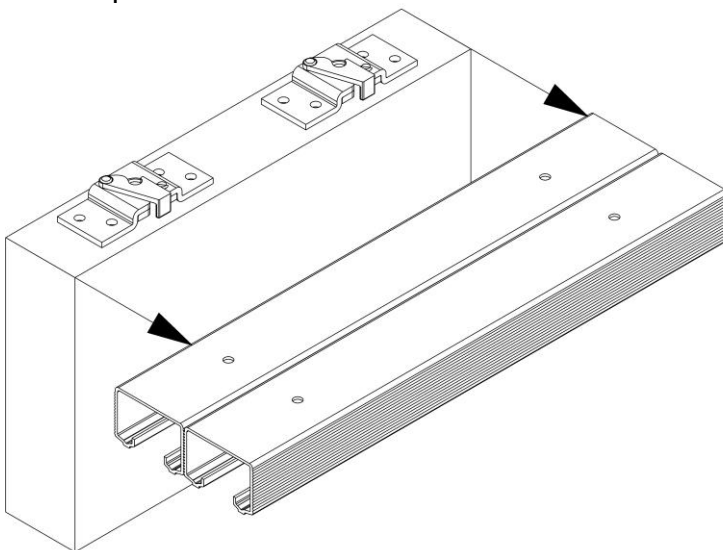

4 ADJUST AND FINISH

- Adjust carriers so door is square with frame
- Install door guides in center of opening, where doors overlap using (#8 X 1-1/2") screws
- Drill appropriate dimensioned hole to mount door pull (optional)
- Install stops (optional)

